

 **ORION**<sup>TM</sup>  
HIGH PERFORMANCE CAR AUDIO

**XTR**<sup>®</sup>

XTR8SWD2    XTR8SWD4  
XTR10SWD2    XTR10SWD4  
XTR12SWD2    XTR12SWD4

**SHALLOW SUBWOOFERS**

**proud to be **LOUD!****



Thank you for purchasing this Orion product. Orion products are specifically engineered and designed for the mobile audio environment. This manual contains important information about installation, set-up procedures and integrating your new Orion product into your vehicle. With proper care and installation, your new product will provide you with many years of high performance listening enjoyment. We recommend having an Authorized Orion Dealer install your new product for optimal performance. Before installing your new product, please read through the manual to fully understand the application.

Before making any electrical connections, make sure that you disconnect the battery's ground cable to prevent the possibility of short circuits or damage to your electronic equipment. If your vehicle's stereo (head unit) comes with an Anti-theft code, DO NOT disconnect the battery. If you have the access code for the stereo (head unit), please refer to the vehicle's owner's manual.

# ATTENTION

## FOR ANY QUESTIONS, ISSUES, RETURNS OR WARRANTY

**DO NOT** contact the retailer, we recommend that you contact our service department for any and all assistance at [support@orioncaraudio.com](mailto:support@orioncaraudio.com).

We will do our best to resolve any problem in a professional and timely manner.



**WARNING:** This product can expose you to chemicals including DEHP which is known to the State of California to cause cancer, birth defects or other reproduction harm. For more information go to [www.P65warnings.ca.gov](http://www.P65warnings.ca.gov).

# TABLE OF CONTENTS



TABLE OF CONTENTS.....	2
SPECIFICATION.....	3-4
WIRING CONFIGURATION.....	5-10
BUILDING AN ENCLOSURE.....	11
ENCLOSURE DETAILS.....	12
ENCLOSURE RECOMMENDATION.....	13-18
WARNING & DISCLAIMER.....	19
TROUBLESHOOTING.....	20
WARRANTY.....	21-22

## WHAT'S IN THE BOX

- 1 x XTR Subwoofer
- 1 x Owner's Manual
- 1 x Window Sticker

# SPECIFICATIONS

<b>SPECIFICATIONS</b>		
Model Number	XTR8SWD2	XTR8SWD4
RMS Power Watts	300W	300W
MAX Power Watts	1200W	1200W
Nom Impedance (Ohm)	2+2	4+4
SPL (dB)	83	83
Frequency	40 - 300 Hz	40 - 300 Hz
Voice Coil Size	2"	2"
Voice Coil Material	Copper	Copper
Magnet Weight	44 Oz	44 Oz
Overall Depth L1(inches)	3.27	3.27
Overall Depth L1(mm)	83	83
Mounting Depth L2(inches)	2.76	2.76
Mounting Depth L2(mm)	70	70
Overall Diameter L2(inches)	8.58	8.58
Overall Diameter L2(mm)	218	218
Mounting Diameter L2(inches)	7.09	7.09
Mounting Diameter L2(mm)	180	180
FS(Hz)	41	44
Qms	2.60	2.07
Qes	0.52	0.64
Qts	0.43	0.49

# SPECIFICATIONS



XTR10SWD2	XTR10SWD4	XTR12SWD2	XTR12SWD4
400W	400W	500W	500W
1600W	1600W	2000W	2000W
2+2	4+4	2+2	4+4
83	83	85	85
35 - 300 Hz	35 - 300 Hz	28 - 300 Hz	28 - 300 Hz
2.5"	2.5"	3"	3"
Copper	Copper	Copper	Copper
53 Oz	53 Oz	56 Oz	56 Oz
4.02	4.02	4.21	4.21
102	102	107	107
3.43	3.43	3.58	3.58
87	87	91	91
10.83	10.83	12.76	12.76
275	275	324	324
9.09	9.09	11.02	11.02
231	231	280	280
35	37	28	32
3.67	2.40	2.88	2.51
0.65	0.84	0.68	0.88
0.52	0.62	0.55	0.65

# WIRING CONFIGURATION

Series - One Speaker (Dual 2 ohm voice coils)

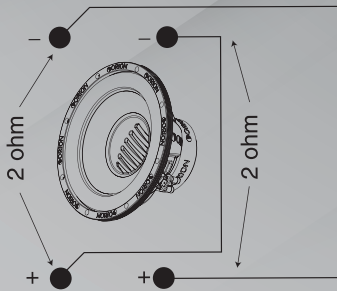

One dual 2 ohm voice coil woofer with voice coils in series results in a 4 ohm load to the amplifier

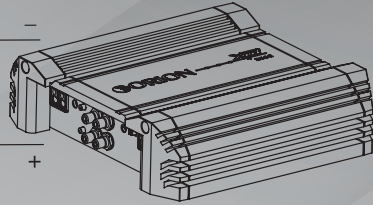

Series - One Speaker (Dual 4 ohm voice coils)

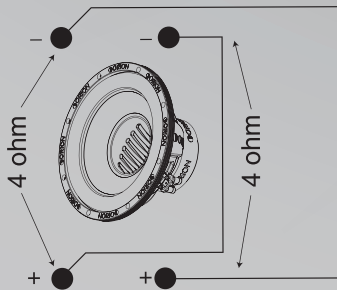

One dual 4 ohm voice coil woofer with voice coils in series results in a 8 ohm load to the amplifier

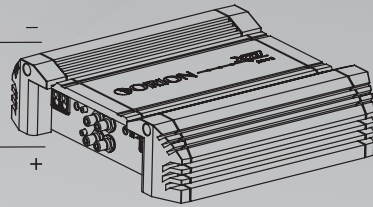

Parallel - One Speaker (Dual 2 ohm voice coils)

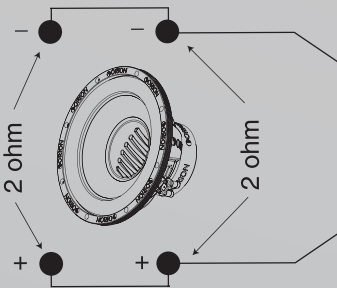

One dual 2 ohm voice coil woofer with voice coils in parallel results in a 1 ohm load to the amplifier

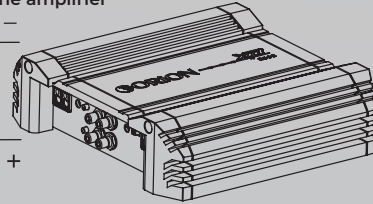

Parallel - One Speaker (Dual 4 ohm voice coils)

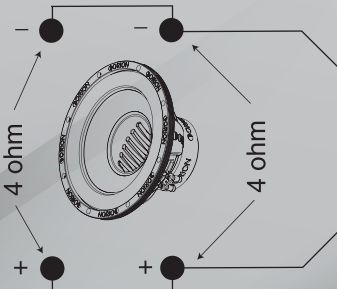

One dual 4 ohm voice coil woofer with voice coils in parallel results in a 2 ohm load to the amplifier

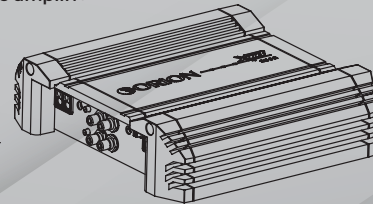

# WIRING CONFIGURATION

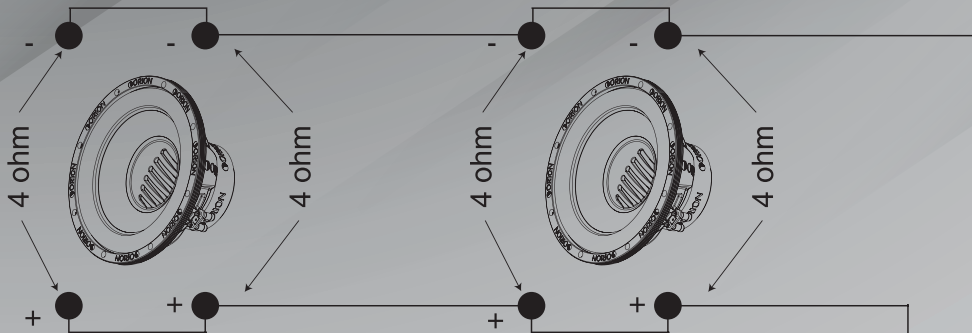

**Parallel - Two Speaker (Dual 4 ohm voice coils)**

Two dual 4 ohm voice coil woofer with voice coils in parallel and the two woofers in parallel results in a 1 ohm load to the amplifier

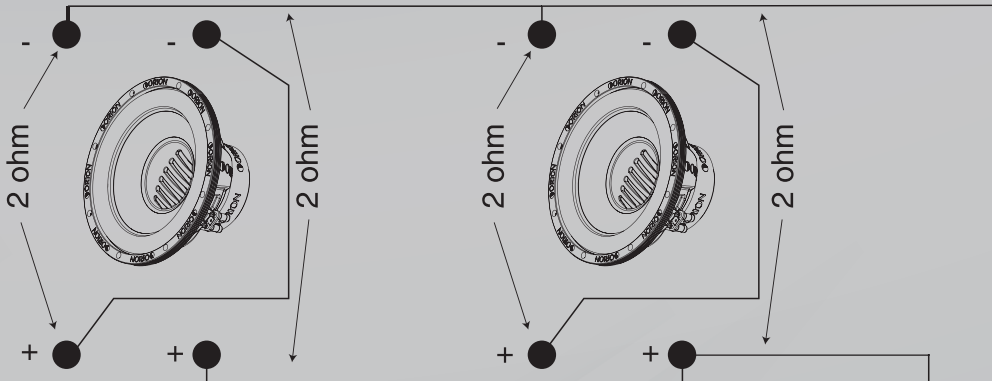
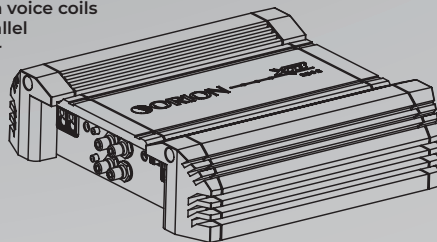

**Series/Parallel - Two Speaker (Dual 2 ohm voice coils)**

Two dual 2 ohm voice coil woofer with voice coils in series and then parallel the two series woofers results in a 2 ohm load to the amplifier

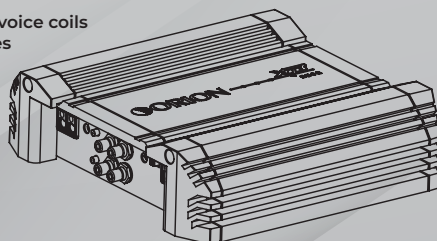

# WIRING CONFIGURATION

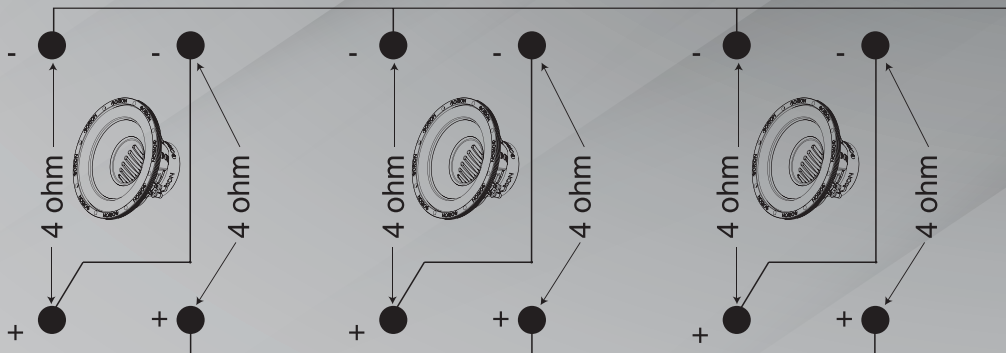

## Series/Parallel - Three Speaker (Dual 4 ohm voice coils)

Three dual 4 ohm voice coil woofer wired in series and then parallel the three woofers for a resulting 2.67 ohm load to the amplifier

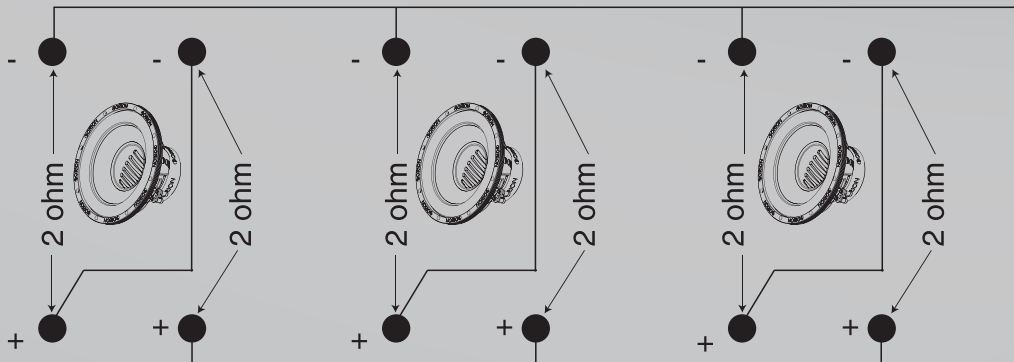
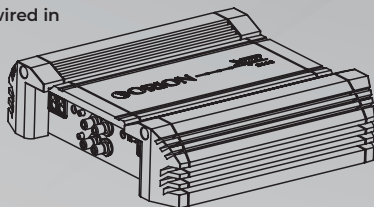

## Series/Parallel - Three Speakers (Dual 2 ohm voice coils)

Three dual 2 ohm voice woofer with voice coils of each woofer wired in series and then parallel the three woofers for a resulting 1.33 ohm load to the amplifier.

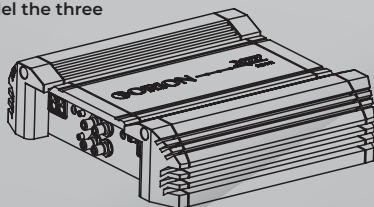



# WIRING CONFIGURATION

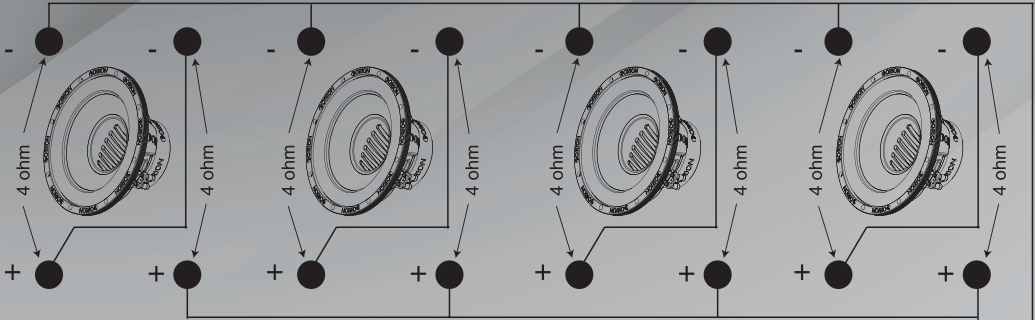

## Series/Parallel - Four Speakers (Dual 4 ohm voice coils)

Four dual 4 ohm voice coil woofers should be wired with the voice coil on each woofer in series and then parallel the four woofers for a resulting 2 ohm load to the amplifier

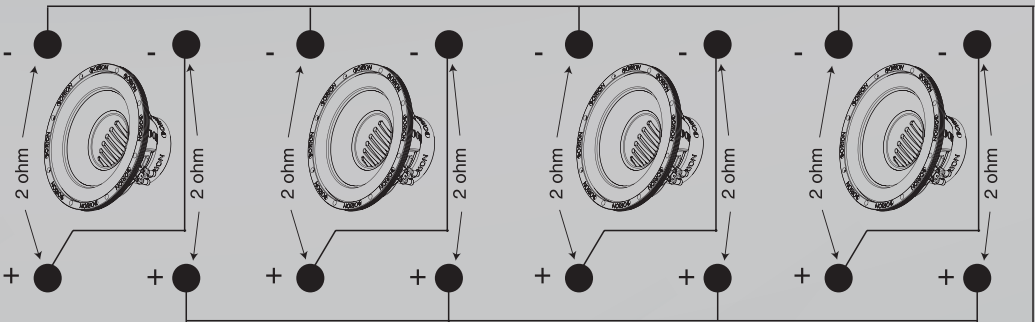
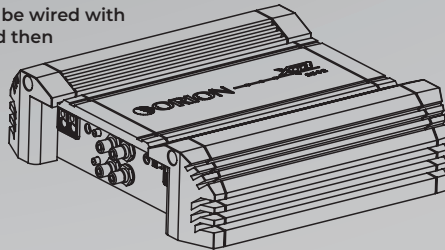

## Series/Parallel - Four Speakers (Dual 2 ohm voice coils)

Four dual 2 ohm voice coil woofers should be wired with the voice coil on each woofer in series and then parallel the four woofers for a resulting 1 ohm load to the amplifier

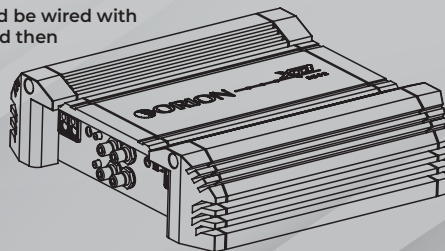

# WIRING CONFIGURATION

## 2 Amplifiers - One Speaker (Dual 4 ohm voice coils)

One dual 4 ohm voice coil woofer with each voice coil connected to an individual amplifier, resulting in a 4 ohm load to each amplifier

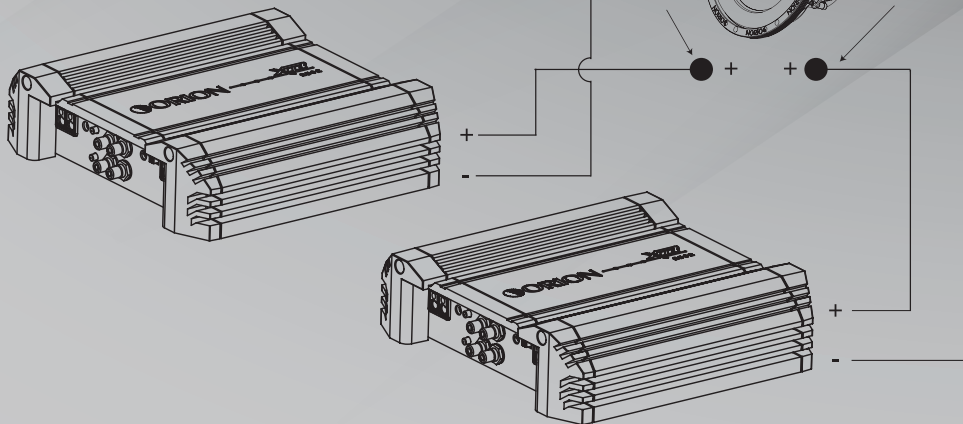

## 2 Amplifiers - One Speaker (Dual 2 ohm voice coils)

One dual 2 ohm voice coil woofer with each voice coil connected to an individual amplifier, resulting in a 2 ohm load to each amplifier

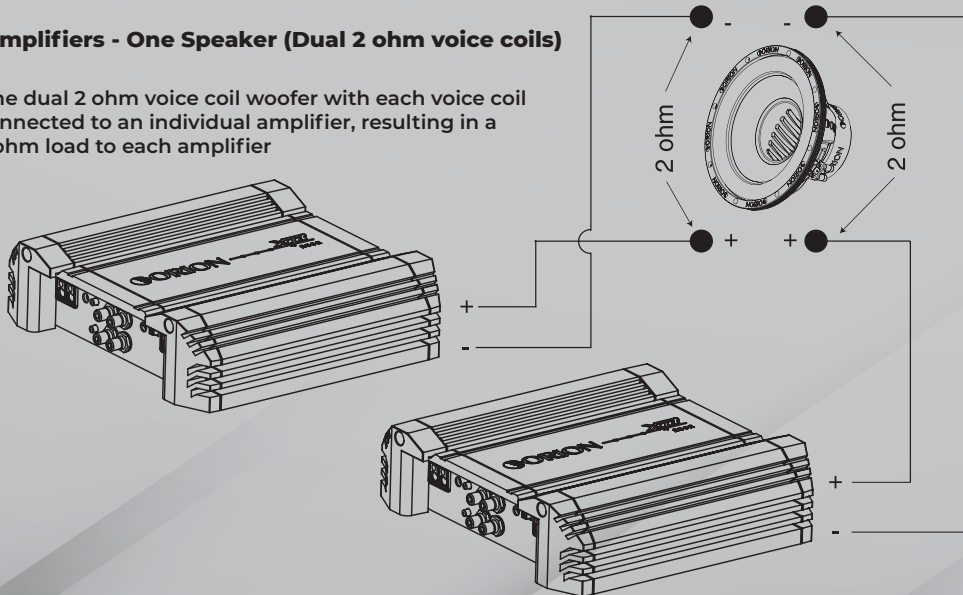

# BUILDING AN ENCLOSURE



If you're planning to build your own enclosure and are confused in what type of enclosure best suits your needs this page will help you choose what enclosure best fits your needs. There are many different types of enclosures. The two most common used enclosures are sealed and vented enclosure. This page will show the advantages and disadvantages of the two enclosures.

## ADVANTAGES OF A SEALED ENCLOSURES

- High power handling capability
- Great transient response
- Tolerant of minor enclosure size variation
- Easy to construct
- Smooth roll off (12dB/octave)

## DISADVANTAGES OF A SEALED ENCLOSURES

- Requires a woofer with a long excursion for better low bass frequency response.
- Can have lower sensitivity than ported enclosures.
- When using high power and small enclosures, the woofer is not in an ideal cooling environment.
- Lower bass as compared to a properly tuned vented enclosure above the ported tuning frequency.

## ADVANTAGES OF A VENTED ENCLOSURE

- Increased output around vented tuning
- Higher power handling above the port tuning frequency
- Extended frequency response
- Magnet is in a good cooling environment
- Handles higher bass frequencies with less distortion

## DISADVANTAGES OF A VENTED ENCLOSURE

- Vented enclosure transient response is not as good as sealed boxes because of the resonant effect of the vent tuning
- Midrange sound coming from inside the enclosure through the vent can produce unpleasant sound coloration.
- Loss of cone movement control below vent tuning, which can result in high distortion and mechanical failure of the driver.
- Lower power handling below the port tuning frequency



# ENCLOSURE DETAILS

## ENCLOSURE DERTAILS

1. Parameters listed are for conventional applications only, for further help please call Sound Pros Tech Support.
2. At least 0.75" MDF (Medium Density Fiberboard) is recommended for any XTR enclosure.
3. Recommended enclosures are NET box volumes, speaker and port displacement are calculated into the volume of the enclosure, you will need to add these volumes to calculate GROSS volume for the enclosure.

## NOTES

\* Due to the high power capabilities and long excursion of the XTR woofers, the Thiele/Small Parameters were calculated and measured using Klippel analyzer system.

\*\* Energy Bandwidth Product (EBP) is determined by the following formula  $F_s/Q_{es}=EBP$ . EBP values of 50 and lower suggest a sealed enclosure is best, 50 to 90 means the subwoofer versatile and 90 and above mean vented Enclosure is recommended.

\*\*\* Subsonic filter should always be used and adjusted specifically for vented box designs.

# ENCLOSURE DETAILS



## XTR8SWD2 & XTR8SWD4 SEALED ENCLOSURE RECOMMENDATIONS

### Box Properties

— Description —  
Type: Closed Box

— Box Parameters —

0.75 cu. ft.

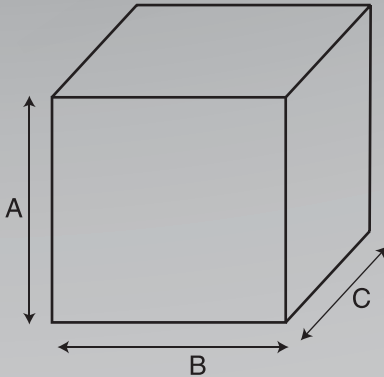

### External Dimensions

A = 12 in. (305 mm)  
B = 12 in. (305 mm)  
C = 13.25 in. (337 mm)

### Internal Dimensions

A = 10.5 in. (267 mm)  
B = 10.5 in. (267 mm)  
C = 12 in. (305 mm)

### Wall Thickness

Front = 0.75 in. (19 mm)  
Side = 0.75 in. (19 mm)

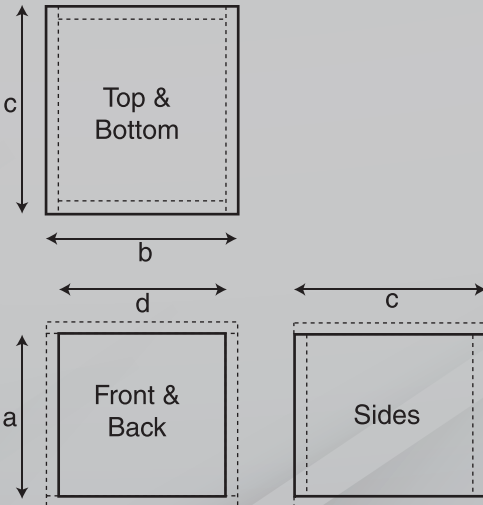

### —Box Parts—

Box Shape: Square Prism

1 Top, 1 Bottom:

depth (c) = 13.25 in. (337 mm)  
width (b) = 12 in. (305 mm)  
thickness = 0.75 in. (19 mm)

1 Front, 1 Back:

height (a) = 10.5 in. (267 mm)  
width (d) = 10.5 in. (267 mm)  
thickness = 0.75 in. (19 mm)

2 Sides: height (a) = 10.5 in. (267 mm)  
depth (c) = 13.25 in. (337 mm)  
thickness = 0.75 in. (19 mm)

### —Driver Mounting—

Front

# ENCLOSURE RECOMMENDATION

## XTR10SWD2 & XTR10SWD4 SEALED ENCLOSURE RECOMMENDATIONS

### Box Properties

— Description —

Type: Closed Box

Shape: Prism, Square

— Box Parameters —

1 cu.ft

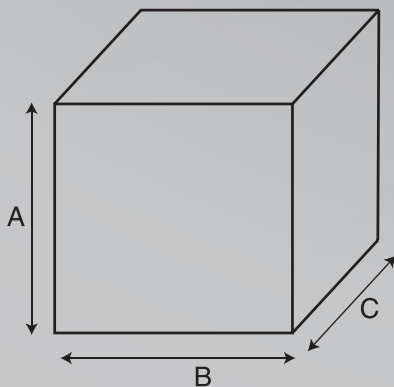

### External Dimensions

A = 13.5 in. (343 mm)

B = 13.5 in. (343 mm)

C = 14.16 in. (360 mm)

### Internal Dimensions

A = 12 in. (305 mm)

B = 12 in. (305 mm)

C = 12.66 in. (322 mm)

### Wall Thickness

Front = 0.75 in. (19 mm)

Side = 0.75 in. (19 mm)

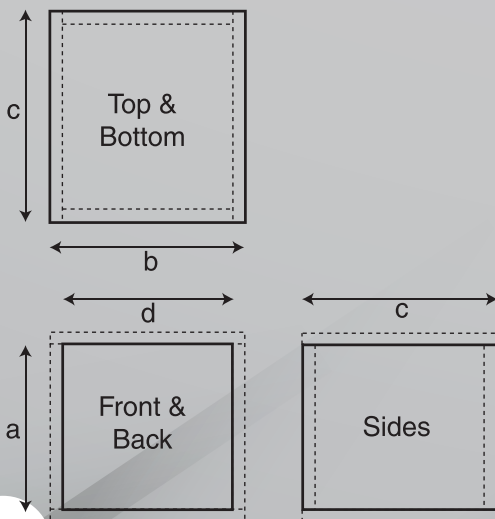

—Box Parts—

Box Shape: Square Prism

1 Top, 1 Bottom:

depth (c) = 14.16 in. (360 mm)

width (b) = 13.5 in. (343 mm)

thickness = 0.75 in. (19 mm)

1 Front, 1 Back:

height (a) = 12 in. (305 mm)

width (d) = 12 in. (305 mm)

thickness = 0.75 in. (19 mm)

2 Sides: height (a) = 12 in. (305 mm)

depth (c) = 14.16 in. (360 mm)

thickness = 0.75 in. (19 mm)

—Driver Mounting—

Front

# ENCLOSURE RECOMMENDATION

## XTR12SWD2 & XTR12SWD4 SEALED ENCLOSURE RECOMMENDATIONS

### Box Properties

— Description —  
Type: Closed Box

— Box Parameters —

1.25 cu. ft.

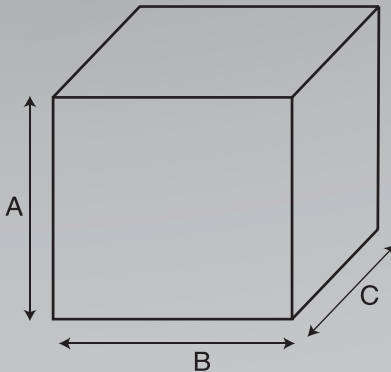

### External Dimensions

A = 14.5 in. (368 mm)  
B = 14.5 in. (368 mm)  
C = 14.25 in. (362 mm)

### Internal Dimensions

A = 13 in. (330 mm)  
B = 13 in. (330 mm)  
C = 12.75 in. (324 mm)

### Wall Thickness

Front = 0.75 in. (19 mm)  
Side = 0.75 in. (19 mm)

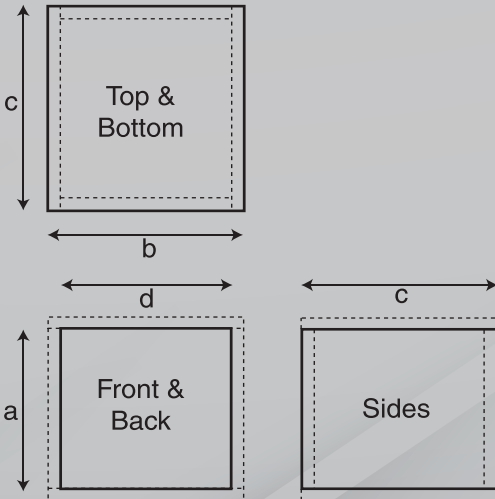

### —Box Parts—

Box Shape: Square Prism

1 Top, 1 Bottom:

depth (c) = 14.25 in. (362 mm)  
width (b) = 14.5 in. (368 mm)  
thickness = 0.75 in. (19 mm)

1 Front, 1 Back:

height (a) = 13 in. (330 mm)  
width (d) = 13 in. (330 mm)  
thickness = 0.75 in. (19 mm)

2 Sides: height (a) = 13 in. (330 mm)  
depth (c) = 14.25 in. (362 mm)  
thickness = 0.75 in. (19 mm)

### —Driver Mounting—

Front

# **WARNING & DISCLAIMER**

Investigate the layout of your vehicle thoroughly before drilling or cutting. Take care when you work near the gas tank, gas lines, hydraulic lines, electrical components and electrical wiring. Do not use the equipment unmounted. Attach this system securely to prevent damage, particularly in the event of an accident or aggressive driving. Do not mount the system so that wire connections are unprotected or are subjected to pinching or damage from nearby objects. Before connecting or disconnecting power connections at the system power terminals, disconnect the +12V DC wire at the battery end. Confirm that your source unit and other equipment are turned off while connecting the input terminals. If you need to replace the power fuse, replace it only with a fuse identical to the amperage recommended. Using a fuse of different type or rating may result in damage to the system, which is not covered by the manufacturer's warranty. Do not install any product where it may be subjected to excessive heat, moisture and dust or where it may be repeatedly kicked, brushed or bumped. Make absolutely sure that the terminals for the products are connected to the proper inputs and outputs from the music source. Never run the wiring on the outside of the vehicle or under it where it can be damaged by road hazards or any moving parts of the vehicle. Use existing wire channels, sills, panels and molding strips inside the vehicle to hide the wiring for safety and a neat appearance.

## **DISCLAIMER**

**IMPORTANT:** Never cut any metal that is an integral part of the vehicle's safety or structural support system. If you are unsure, it is best to have the product professionally installed by an Authorized ORION Dealer. Never sacrifice your safety for sound.



# TROUBLESHOOTING



Symptom	Check Point	Remedy
No Soud	Is the amplifier power LED illuminated?	1. Check fuses in amplifier 2. Check turn-on lead 3. Check signal lead 4. Check gain control 5. Check source unit volume 6. Clean contacts on fuse holders
	Is the amplifier overload LED illuminated?	Check speaker for short or amplifier for overheating
	Check impedance with Ohm meter	If no reading, replace speaker
	Check that the speaker moves freely	If speaker won't move, replace speaker
Speaker is making a rattling noise	Check that speaker is secured properly and tightened with screws	Tighten mounting screws
	Check enclosure construction	Check that the enclosure is debris free
	Check speaker polarity	Correct polarity
No sound from one coil	Check speaker leads	1. Inspect for short circuits 2. Check for open connections  Reverse left and right speaker leads to determine if it is occurring before the speaker
Speaker is distorting at high volume levels	Check speaker load impedance capabilities for the amplifier	Confirm that the speaker load impedance recommendations are followed. Check the wiring configuration of the speaker. (To verify proper load impedance, use an OHM meter to measure the total load for each channel of the amplifier.
	Verify that amplifier and/or crossover settings are correct	Select low-pass setting

# WARRANTY

Orion, warrants this product against all defects in material and workmanship for a period of one (1) year from the date of original purchase provided it was purchased from an Authorized Orion Dealer.

The conditions of this warranty and the extent of the responsibility of Orion, under this warranty are as follows:

1. DATED PROOF OF PURCHASE IS REQUIRED FOR WARRANTY SERVICE OF THIS PRODUCT. Information about Orion authorized warranty service may also be obtained at [www.orioncaraudio.com](http://www.orioncaraudio.com) or by emailing Orion at [support@orioncaraudio.com](mailto:support@orioncaraudio.com).
2. This warranty will become void if service is performed by anyone other than an approved Orion Warranty Service Center.
3. This warranty does not apply to any product which has been subjected to misuse, neglect or accident, or which has had the warranty seal broken, serial number altered, defaced or removed, or which has been connected, installed adjusted or repaired other than in accordance with the instructions furnished by Orion.
4. This warranty does not cover car static, electrical interference, adjustments or labor costs for the removal or reinstallation of the unit for repair.
5. The sole responsibility of Orion under this warranty shall be limited to the repair or replacement thereof, at the sole discretion of Orion.
6. If it becomes necessary to send the product or any defective part to Orion or an authorized service station, the product must be shipped in its original or equivalent carton, fully insured, with shipping charges prepaid. Orion will not assume any responsibility for any loss or damage incurred in shipping.

# WARRANTY

7. This warranty is not transferable and protects the original purchaser provided they reside and made their purchase in the United States. International consumers may contact their local retailer or distributor for warranty information.
8. ALL IMPLIED WARRANTIES, EXCEPT TO THE EXTENT PROHIBITED BY APPLICABLE LAW, SHALL HAVE NO GREATER DURATION THAN THE WARRANTY PERIOD SET FORTH ABOVE. UNDER NO CIRCUMSTANCES SHALL ORION BE LIABLE FOR ANY LOSS OR DAMAGE, DIRECT OR CONSEQUENTIAL, ARISING OUT OF THE USE OR INABILITY TO USE THE PRODUCT BECAUSE SOME STATES DO NOT ALLOW LIMITATIONS ON HOW LONG AN IMPLIED WARRANTY LASTS OR EXCLUSIONS OR LIMITATIONS OF INCIDENTAL OR CONSEQUENTIAL DAMAGES, THE ABOVE LIMITATIONS OR EXCLUSIONS MAY NOT APPLY TO YOU.
9. THIS WARRANTY GIVES YOU SPECIFIC LEGAL RIGHTS AND YOU MAY ALSO HAVE OTHER RIGHTS THAT VARY FROM STATE TO STATE.
10. Should you have any difficulties with the performance of this product during warranty or with any Orion authorized service center, you may contact Orion by emailing us at [support@orioncaraudio.com](mailto:support@orioncaraudio.com).

## **ATTENTION**

### **FOR ANY QUESTIONS, ISSUES, RETURNS OR WARRANTY**

**DO NOT** contact the retailer, we recommend that you contact our service department for any and all assistance at [support@orioncaraudio.com](mailto:support@orioncaraudio.com).

We will do our best to resolve any problem in a professional and timely manner.



3130 WEST 15TH AVENUE HIALEAH, FLORIDA 33012  
TEL: 786.464.0247 EMAIL: SUPPORT@ORIONCARAUDIO.COM ORIONCARAUDIO.COM

---

PROUD SPONSOR OF



Copyright ORION

All rights reserved. Any unauthorized reproduction or use of any Orion logos, images or design elements is strictly prohibited by law. Specifications subject to change without notice. REV. 24.3