

 **ORION**TM
HIGH PERFORMANCE CAR AUDIO



XTRPRO802D XTRPRO804D
XTRPRO102D XTRPRO104D
XTRPRO122D XTRPRO124D
XTRPRO152D XTRPRO154D

SUBWOOFERS

proud to be LOUD!

TABLE OF CONTENTS

Thank you for purchasing this Orion product. Orion products are specifically engineered and designed for the mobile audio environment. This manual contains important information about installation, set-up procedures and integrating your new Orion product into your vehicle. With proper care and installation, your new product will provide you with many years of high performance listening enjoyment. We recommend having an Authorized Orion Dealer install your new product for optimal performance. Before installing your new product, please read through the manual to fully understand the application.

Before making any electrical connections, make sure that you disconnect the battery's ground cable to prevent the possibility of short circuits or damage to your electronic equipment. If your vehicle's stereo (head unit) comes with an Anti-theft code, DO NOT disconnect the battery. If you have the access code for the stereo (head unit), please refer to the vehicle's owner's manual.

TABLE OF CONTENTS.....2

FEATURES.....3

SPECIFICATION.....4

WIRING CONFIGURATION.....5-14

BUILDING AN ENCLOSURE.....15

ENCLOSURE DETAILS.....16-17

ENCLOSURE RECOMMENDATION.....18-25

WARNING & DISCLAIMER.....26

TROUBLESHOOTING.....27

WARRANTY.....28

ATTENTION

FOR ANY QUESTIONS, ISSUES, RETURNS OR WARRANTY

DO NOT contact the retailer, we recommend that you contact our service department for any and all assistance at support@orioncaraudio.com.

We will do our best to resolve any problem in a professional and timely manner.

WHAT'S IN THE BOX

- 1 x XTRPRO Subwoofer
- 1 x Trim Ring
- 1 x Mounting Template
- 1 x Owner's Manual
- 1 x Window Sticker



WARNING: This product can expose you to chemicals including DEHP which is known to the State of California to cause cancer, birth defects or other reproduction harm. For more information go to www.P65warnings.ca.gov.

FEATURES

SPECIFICATIONS

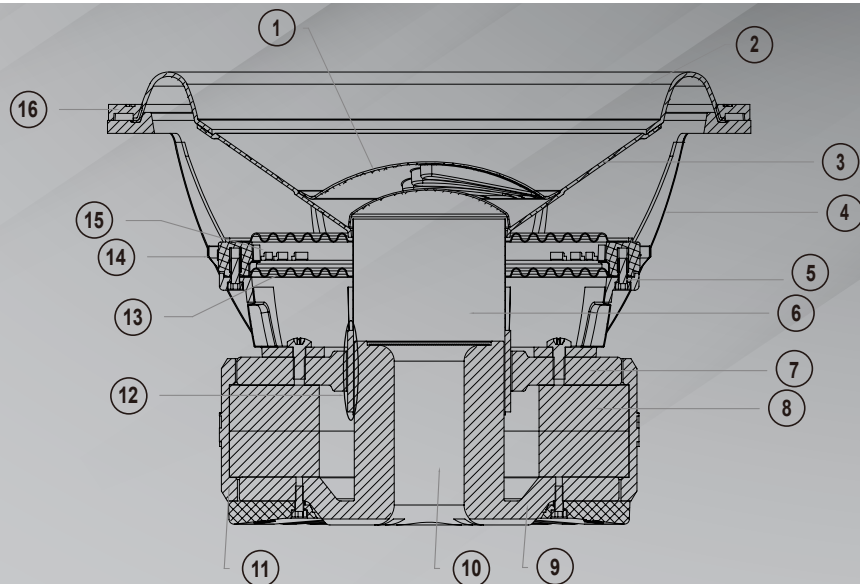

1	Polypropylene dust cap - moisture and UV resistant.
2	Oversized Santoprene surround for linear controlled long excursion.
3	Vented paper cone - moisture and UV resistant.
4	Custom stamped aluminum frame.
5	Spider ring attachment screws.Part of re-cone feature (8 hex screws)
6	Vented Kapton voice coil former (8" & 10" uses 2.5" voice coil former, 12" & 15" use a 3" voice coil former).
7	20mm H type steel front plate
8	Large 2 stack ceramic magnets (15" use large 3 stack ceramic magnets).
9	12mm steel back plate/pole piece T yoke assembly.
10	1.2"(8" & 10" speaker) & 1.4"(12" & 15" speaker) vent. Part of the enhanced voice coil cooling system (forced convection).
11	PVC magnet protector.
12	High temperature Aluminum voice coil wound.Dual 2 and 4 ohm voice coils available.
13	Dual Interlaced Conex spider with stitched and looped tinsel leads attached.
14	Custom allen head screw terminals.A pair on each side(one pair for each voice coil).
15	Spider space and spider mounting ring assembly part of field re-cone kit attachment method.(eight allen head screws).
16	Surround clamp ring,part of fiele re-cone kit attachment method.(8", 10" & 12" use eight allen head screws, 15" use twelve allen head screws).

	XTRPRO802D	XTRPRO804D	XTRPRO102D	XTRPRO104D	XTRPRO122D	XTRPRO124D	XTRPRO152D	XTRPRO154D
Fs (free-air resonance, Hz)	54.5	57.1	45	45.1	34.6	35.7	29.8	30.5
Vas (equivalent compliance, cu. ft.)	0.21	0.19	0.4157	0.4193	1.0932	1.114	3.029	3.000
Vas (equivalent compliance, liters)	5.8112	5.3384	11.7715	11.8737	30.9584	31.5591	85.7935	84.9616
Qms (Q, mechanical)	9.47	8.567	13.508	14.074	15.168	14.569	15.029	14.963
Qes (Q, electrical)	0.5	0.542	0.559	0.609	0.551	0.616	0.55	0.632
Qts (total driver Q)	0.475	0.51	0.537	0.584	0.531	0.591	0.53	0.607
Re (DC resistance, ohms)	3.6	6.8	3.61	6.84	3.73	7.01	3.66	7.02
Z (nominal impedance, ohms)	2+2	4+4	2+2	4+4	2+2	4+4	2+2	4+4
Efficiency (1W @ 1M, dB)	84.75	84.67	87.8	88.7	88.6	89.3	90.9	90.5
Efficiency (2.86V @1 M, dB)	85.23	85.38	90.8	88.7	91.6	89.3	93.9	90.5
Le (inductance, mh	2.2	3.6	2.293	3.797	2.392	3.723	2.449	3.752
Xmas (one way linear excursion, in.)	0.48	0.48	0.472	0.472	0.528	0.528	0.528	0.528
Xmas (one way linear excursion, mm)	12.2	12.2	12	12	13.4	13.4	13.4	13.4
RMS POWER WATTS	1000	1000	1250	1250	1500	1500	2000	2000
MAX MUSIC POWER WATTS	4000	4000	5000	5000	6000	6000	8000	8000
Mms (total moving mass, grams)	150.253	148.627	201.643	199.545	280.753	259.42	395.322	383.922
Cms (mechanical compliance, m/N)	0.057	0.052	0.0094	0.062	0.075	0.077	0.083	0.078
Bl (motor strength, Tesla-M)	19.221	25.866	19.18	25.182	20.345	25.712	21.457	27.893
Sd (effective radiating area, sq. cm.)	268.8	268.8	366.44	366.44	539.13	539.13	876.16	876.16
Sd)effective radiating area, sq. in.)	41.66	41.66	56.798	56.798	83.565	83.565	135.805	135.805
Frequency Range (Hz)	40-150Hz	40-150Hz	35 - 150Hz	35 - 150Hz	32 - 150Hz	32 - 150Hz	28 - 150Hz	28 - 150Hz
Energy Bandwidth Product (EBP)**	109	105	80	74	62	57	54	48

WIRING CONFIGURATION

Series - One Speaker (dual 2 ohm voice coils)

One dual 2 ohm voice coil woofer with voice coils in connected in series results in a 4 ohm load to the amplifier.

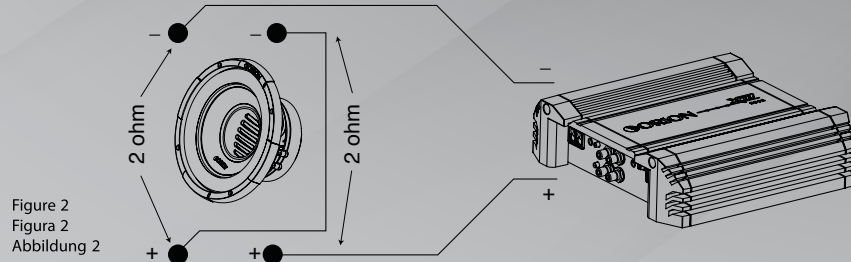

1. Connect the woofer in series by connecting the negative (-) of one terminal to the positive (+) terminal of the other coil.
2. Wire the positive (+) terminal of the first coil to the positive (+) terminal on the amplifier. Wire the negative (-) terminal of the second coil to the negative (-) terminal on the amplifier.

Parallel—One Speaker (dual 2 ohm voice coils)

One dual 2 ohm voice coil woofer with voice coils in parallel results in a 1 ohm load to the amplifier.

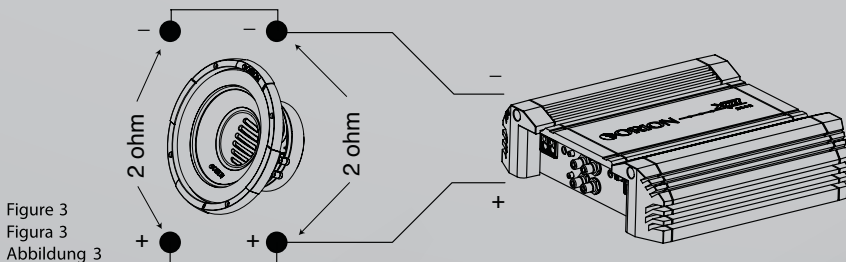

1. Connect the speaker in parallel by connecting the two positive (+) terminals together and the two negative (-) terminals together.
2. Wire the positive (+) terminals of the woofer to the positive (+) terminal on the amplifier. Wire the negative (-) terminals of the woofer to the negative (-) terminal on the amp.

WIRING CONFIGURATION

Parallel — One Speaker (dual 4 ohm voice coils)

One dual 4 ohm voice coil woofer with voice coils in parallel results in a 2 ohm load to the amplifier.

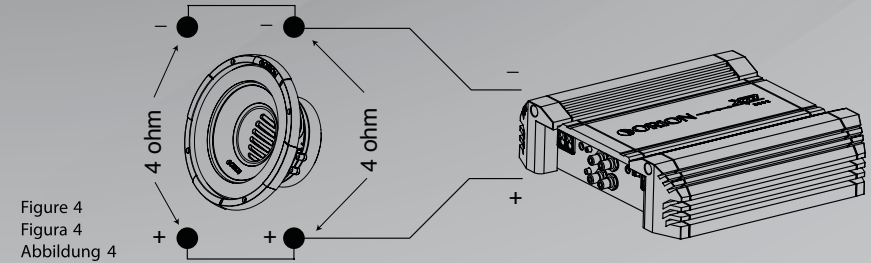

1. Connect the speaker in parallel by connecting the two positive (+) terminals together and the two negative (-) terminals together.
2. Wire both positive (+) terminals of the woofer to the positive (+) terminal on the amplifier. Wire both negative (-) terminals of the woofer to the negative (-) terminal on the amplifier.

WIRING CONFIGURATION

Parallel - Two Speaker (dual 4 ohm voice coils)

Two dual 4 ohm voice coil woofers with voice coils in parallel and the two woofers in parallel results in a 1 ohm load to the amplifier.

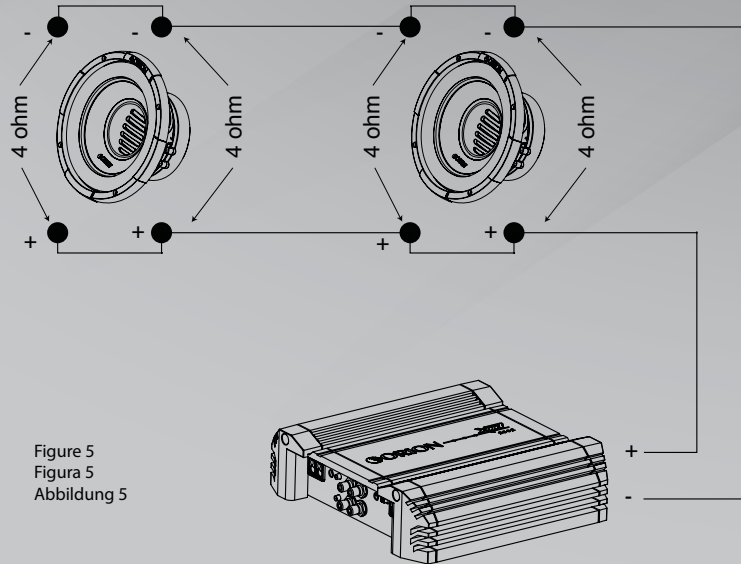

Figure 5
Figura 5
Abbildung 5

1. Connect the speaker in parallel by connecting the four positive (+) terminals together and the four negative (-) terminals together.
2. Wire the positive (+) terminals of the woofers to the positive (+) terminal on the amplifier. Wire the negative (-) terminals of the woofers to the negative (-) terminal on the amplifier.

WIRING CONFIGURATION

Series/Parallel - Two Speakers (dual 2 ohm voice coils)

Note: Verify and ensure that the woofer wiring is connected as shown with the negative connection from the first woofer coil connected to the positive connection of the second woofer coil.

Two dual 2 ohm voice coil woofers with voice coils in series and then parallel the two series woofers results in a 2 ohm load to the amplifier.

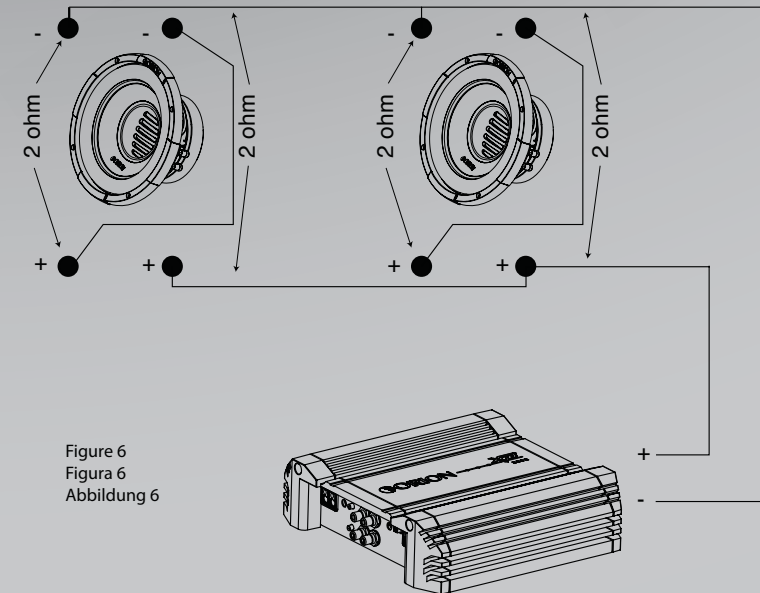

Figure 6
Figura 6
Abbildung 6

1. Connect each woofer in series by connecting the negative (-) of the first coil to the positive (+) terminal of the second coil.
2. Wire the positive (+) terminal of the first coil on each woofer to the positive (+) terminal on the amplifier. Wire the negative (-) terminal of the second coil on each woofer to the negative (-) terminal on the amplifier.

WIRING CONFIGURATION

Series/Parallel - Three Speakers (dual 4 ohm voice coils)

Note: Verify and ensure that the woofer wiring is connected as shown with the negative connection from the first woofer coil connected to the positive connection of the second woofer coil.

Three dual 4 ohm voice coil woofer with voice coils of each woofer wired in series and then parallel the three woofers for a resulting 2.67 ohm load to the amplifier.

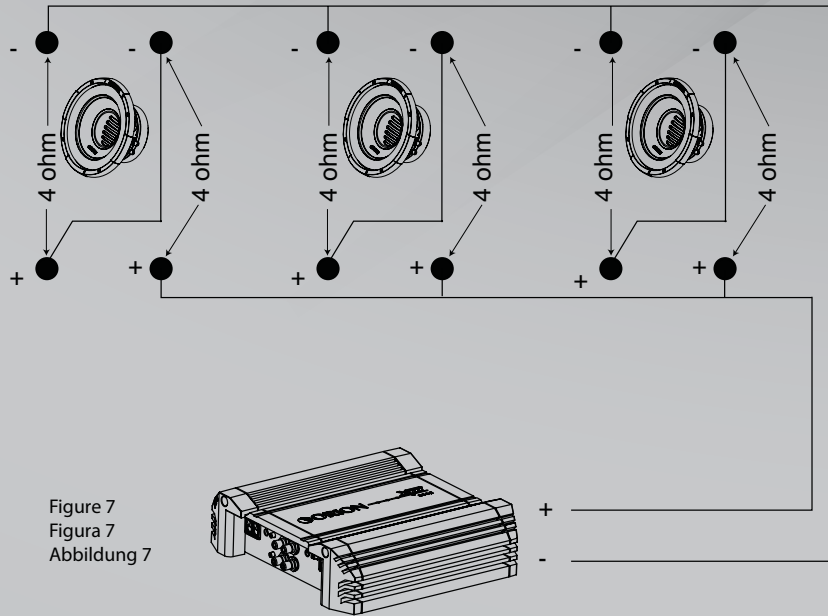

Figure 7
Figura 7
Abbildung 7

1. Connect each woofer in series by connecting the negative (-) of the first coil to the positive (+) terminal of the second coil.
2. Wire the positive (+) terminal of each woofer's first coil to the positive (+) terminal on the amplifier. Wire the negative (-) terminal of each woofer's second coil to the negative (-) terminal on the amplifier.

WIRING CONFIGURATION

Series/Parallel - Three Speakers (dual 2 ohm voice coils)

Note: Verify and ensure that the woofer wiring is connected as shown with the negative connection from the first woofer coil connected to the positive connection of the second woofer coil.

Three dual 2 ohm voice coil woofer with voice coils of each woofer wired in series and then parallel the three woofers for a resulting 1.33 ohm load to the amplifier.

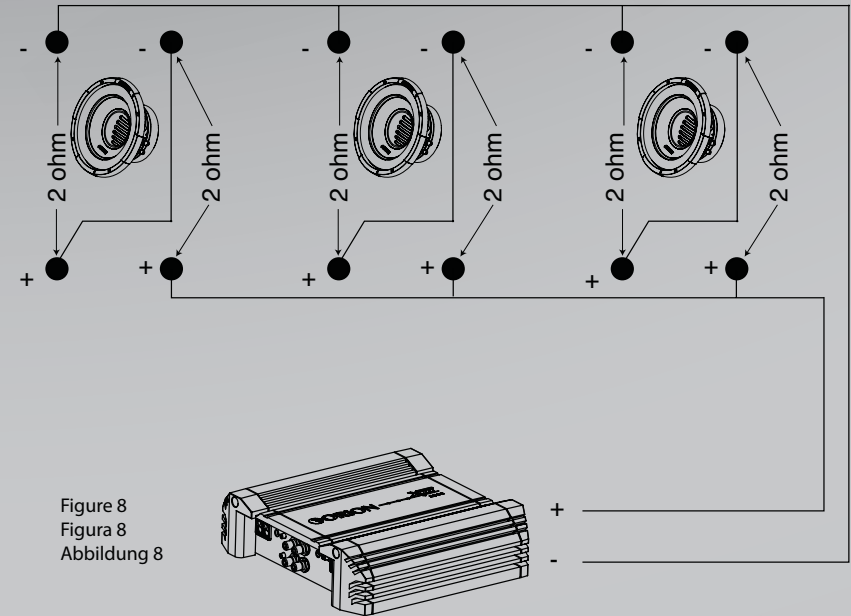

Figure 8
Figura 8
Abbildung 8

1. Connect each woofer in series by connecting the negative (-) of the first coil to the positive (+) terminal of the second coil.
2. Wire the positive (+) terminal of each woofer's first coil to the positive (+) terminal on the amplifier. Wire the negative (-) terminal of each woofer's second coil to the negative (-) terminal on the amplifier.

WIRING CONFIGURATION

Series/Parallel - Four Speakers (dual 4 ohm voice coils)

Note: Verify and ensure that the woofer wiring is connected as shown with the negative connection from the first woofer coil connected to the positive connection of the second woofer coil.

Four dual 4 ohm voice coil woofers should be wired with the voice coils on each woofer in series and then parallel the four woofers for a resulting 2 ohm load to the amplifier.

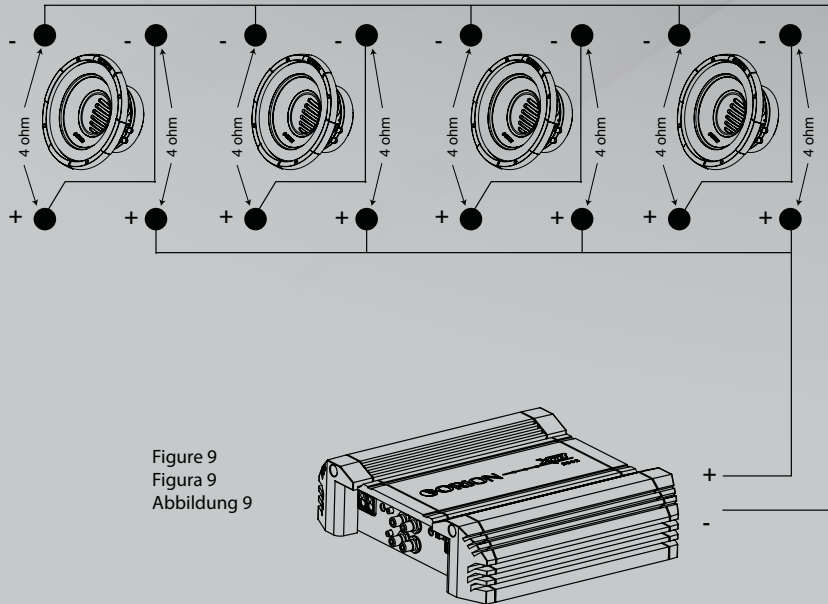

Figure 9
Figura 9
Abbildung 9

1. Connect each woofer in series by connecting the negative (-) of the first coil to the positive (+) terminal of the second coil.
2. Wire the positive (+) terminals of the first coil of each woofer to the positive (+) terminal on the amplifier. Wire the negative (-) terminal of the second coil of each woofer to the negative (-) terminal on the amplifier.

WIRING CONFIGURATION

Series/Parallel - Four Speakers (dual 2 ohm voice coils)

Note: Verify and ensure that the woofer wiring is connected as shown with the negative connection from the first woofer coil connected to the positive connection of the second woofer coil.

Four dual 2 ohm voice coil woofers should be wired with the voice coils on each woofer in series and then parallel the four woofers for a resulting 1 ohm load to the amplifier.

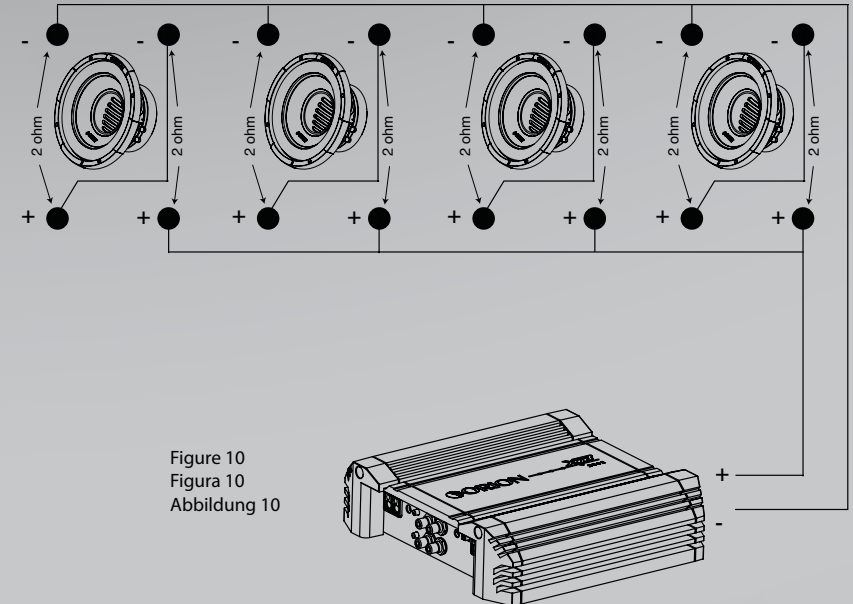

Figure 10
Figura 10
Abbildung 10

1. Connect each woofer in series by connecting the negative (-) of the first coil to the positive (+) terminal of the second coil.
2. Wire the positive (+) terminals of the first coil of each woofer to the positive (+) terminal on the amplifier. Wire the negative (-) terminal of the second coil of each woofer to the negative (-) terminal on the amplifier.

WIRING CONFIGURATION

2 Amplifiers - One Speaker (dual 2 ohm voice coils)

One dual 2 ohm voice coil woofer with each voice coil connected to an individual amplifier, resulting in a 2 ohm load to each amplifier.

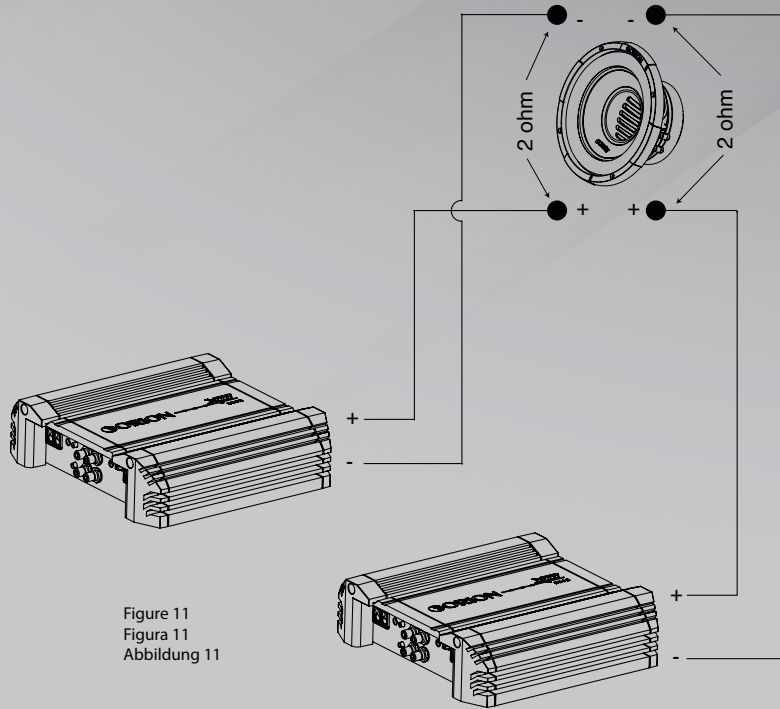

Figure 11
Figura 11
Abbildung 11

1. Connect one of the speaker's voice coils to the first amplifier by connecting the positive (+) terminal and the negative (-) terminal from the speaker to the respective positive (+) terminal and the negative (-) terminal from the first amplifier.
2. Connect the other of the speaker's voice coils to the second amplifier by connecting the positive (+) terminal and negative (-) terminal from the speaker to the respective positive (+) terminal and the negative (-) terminal from second amplifier.

WIRING CONFIGURATION

2 Amplifiers - One Speaker (dual 4 ohm voice coils)

One dual 4 ohm voice coil woofer with each voice coil connected to an individual amplifier, resulting in a 4 ohm load to each amplifier.

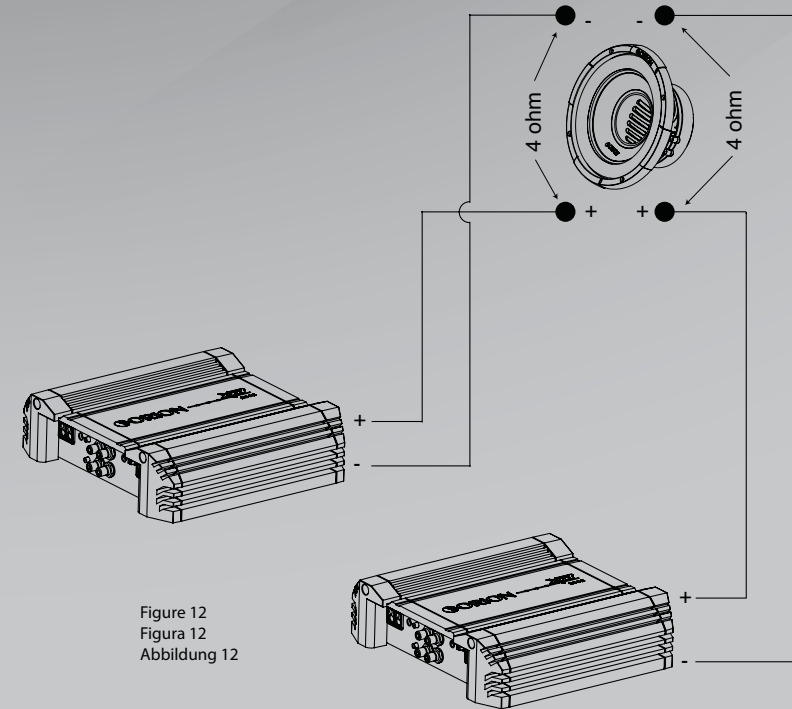

Figure 12
Figura 12
Abbildung 12

1. Connect one of the speaker's voice coils to the first amplifier by connecting the positive (+) terminal and the negative (-) terminal from the speaker to the respective positive (+) terminal and the negative (-) terminal from the first amplifier.
2. Connect the other of the speaker's voice coils to the second amplifier by connecting the positive (+) terminal and negative (-) terminal from the speaker to the respective positive (+) terminal and the negative (-) terminal from second amplifier.

If you're planning to build your own enclosure and are confused in what type of enclosure best suits your needs this page will help you choose what enclosure best fits your needs. There are many different types of enclosures. The two most common used enclosures are sealed and vented enclosure. This page will show the advantages and disadvantages of the two enclosures.

ADVANTAGES OF A SEALED ENCLOSURES

- High power handing capability
- Great transient response
- Tolerant of minor enclosure size variation
- Easy to construct
- Smooth roll off (12dB/octave)

DISADVANTAGES OF A SEALED ENCLOSURES

- Requires a woofer with a long excursion for better low bass frequency response.
- Can have lower sensitivity than ported enclosures.
- When using high power and small enclosures, the woofer is not in an ideal cooling environment.
- Lower bass as compared to a properly tuned vented enclosure above the ported tuning frequency.

ADVANTAGES OF A VENTED ENCLOSURE

- Increased output around vented tuning
- Higher power handling above the port tuning frequency
- Extended frequency response
- Magnet is in a good cooling environment
- Handles higher bass frequencies with less distortion

DISADVANTAGES OF A VENTED ENCLOSURE

- Vented enclosure transient response is not as good as sealed boxes because of the resonant effect of the vent tuning
- Midrange sound coming from inside the enclosure through the vent can produce unpleasant sound coloration.
- Loss of cone movement control below vent tuning, which can result in high distortion and mechanical failure of the driver.
- Lower power handling below the port tuning frequency

ENCLOSURE DETAILS

1. Parameters listed are for conventional applications only, for further help please call Sound Pros Tech Support.
2. At least 0.75" MDF (Medium Density Fiberboard) is recommended for any XTR enclosure.
3. Recommended enclosures are NET box volumes, speaker and port displacement are calculated into the volume of the enclosure, you will need to add these volumes to calculate GROSS volume for the enclosure.

NOTES

- * Due to the high power capabilities and long excursion of the XTR woofers, the Thiele/Small Parameters were calculated and measured using Klippel analyzer system.
- ** Energy Bandwidth Product (EBP) is determined by the following formula $F_s/Q_{es}=EBP$. EBP values of 50 and lower suggest a sealed enclosure is best, 50 to 90 means the subwoofer versatile and 90 and above mean vented Enclosure is recommended.
- *** Subsonic filter should always be used and adjusted specifically for vented box designs.

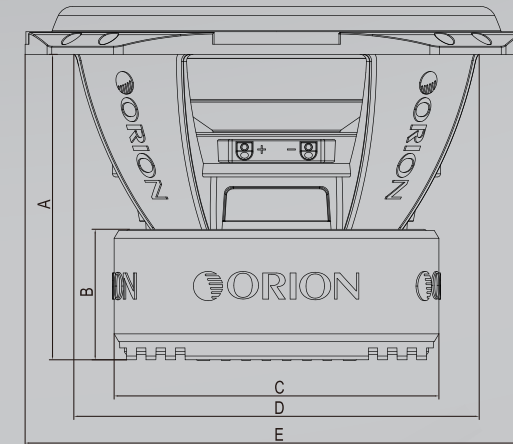

Figure 13
Figura 13
Abbildung 13

	XTRPRO802D	XTRPRO804D	XTRPRO102D	XTRPRO104D	XTRPRO122D	XTRPRO124D	XTRPRO152D	XTRPRO154D
Dimensions inches/mm, Dimensions po/mm, Dimensiones plg./mm, Abmessungen Zoll/mm, Dimensioni pollici/millimetri, Dimensões polegadas/mm								
A	6.96/176.8	6.96/176.8	7.27/184.6	7.27/184.6	7.70/195.6	7.70/195.6	9.59/243.6	9.59/243.6
B	3.04/77.3	3.04/77.3	3.06/77.6	3.06/77.6	3.29/83.6	3.29/83.6	4.43/112.6	4.43/112.6
C	6.97/177	6.97/177	7.32/186	7.32/186	8.19/208	8.19/208	8.98/228	8.98/228
D	7.99/202.9	7.99/202.9	9.25/235	9.25/235	11.18/284	11.18/284	14.33/364	14.33/364
E	8.07/205	8.07/205	10.67/271	10.67/271	12.68/322	12.68/322	15.83/402	15.83/402

Driver Physical Dimension		XTRPRO802D		XTRPRO804D		XTRPRO102D		XTRPRO104D		XTRPRO122D		XTRPRO124D		XTRPRO152D		XTRPRO154D	
Speaker Displacement (cu ft)	0.06	0.06	0.1204	0.1204	0.1674	0.1674	0.2703	0.2703	0.2703	0.2703	0.2703	0.2703	0.2703	0.2703	0.2703	0.2703	0.2703
Mounting hole diameter (inches/mm)	7.99/202.9	7.99/202.9	11.34/288	11.34/288	13.35/339	13.35/339	16.61/422	16.61/422	16.61/422	16.61/422	16.61/422	16.61/422	16.61/422	16.61/422	16.61/422	16.61/422	16.61/422
Mounting depth (inches/mm)	6.96/176.8	6.96/176.8	7.27/185	7.27/185	7.70/196	7.70/196	9.59/244	9.59/244	9.59/244	9.59/244	9.59/244	9.59/244	9.59/244	9.59/244	9.59/244	9.59/244	9.59/244
Magnet Weight (Oz)	125	125	133	133	176	176	373	373	373	373	373	373	373	373	373	373	373
Recommended Enclosures																	
Typical sealed enclosure (cu ft)	0.50	0.50	0.75	0.75	1.5	1.5	2	2	2	2	2	2	2	2	2	2	2
Vented enclosure (cu. ft.)***	0.75	0.75	0.75	0.75	1.5	1.5	3	3	3	3	3	3	3	3	3	3	3
Port tuning frequency (Hz)	44	44	44	44	40	40	35	35	35	35	35	35	35	35	35	35	35
Port diameter (inside, inches)	3	3	3	3	4	4	4	4	4	4	4	4	4	4	4	4	4
Port square equivalent (inches)	2.659x2.659	2.659	2.659 x 2.659	2.659 x 2.659	3.545 x 3.545	3.545 x 3.545	3.545 x 3.545	3.545 x 3.545	3.545 x 3.545	3.545 x 3.545	3.545 x 3.545	3.545 x 3.545	3.545 x 3.545	3.545 x 3.545	3.545 x 3.545	3.545 x 3.545	3.545 x 3.545
Port length (inches)	11.19	11.19	11.19	11.19	11.26	11.26	5.42	5.42	5.42	5.42	5.42	5.42	5.42	5.42	5.42	5.42	5.42

Enclosure Details

- External dimensions calculated for 3/4" building material
- Includes speaker displacement
- Volumes given are net tuning volume
- Enclosures include a minimal amount of damping material. Just enough material to line the inside of the enclosure is required.

XTRPRO802D & 804D Sealed Enclosure Recommendations

Box Properties

— Description —
Type: Closed Box
Shape: Prism, Square

— Box Parameters —
Vb = 0.50 cu.ft
V(total) = 0.56 cu.ft
Qtc = 0.566
QL = 10
F3 = 84.85 Hz
Fill = none

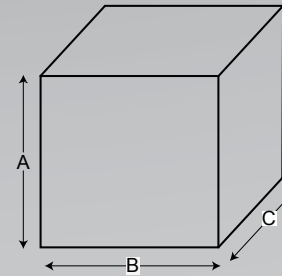

External Dimensions
A = 13.5 in. (343 mm)
B = 13.5 in. (343 mm)
C = 7.5 in. (274 mm)
Internal Dimensions
A = 12 in. (305 mm)
B = 12 in. (305 mm)
C = 6 in. (152 mm)
Wall Thickness
Front = 0.75 in. (19 mm)
Side = 0.75 in. (19 mm)

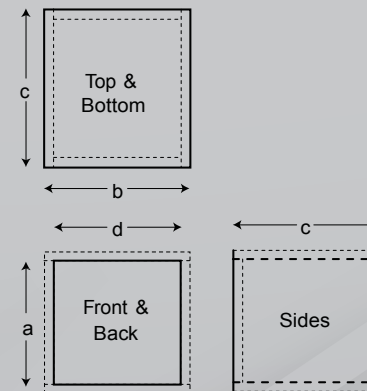

—Box Parts—
Box Shape: Square Prism
1 Top, 1 Bottom:
depth (c) = 7.5 in. (191 mm)
width (b) = 13.5 in. (343 mm)
thickness = 0.75 in. (19 mm)
1 Front, 1 Back:
height (a) = 12 in. (305 mm)
width (d) = 12 in. (305 mm)
thickness = 0.75 in. (19 mm)
2 Sides: height (a) = 12 in. (305 mm)
depth (c) = 7.5 in. (191 mm)
thickness = 0.75 in. (19 mm)

—Driver Mounting—
Mounting: Front

Figure 14
Figura 14
Abbildung 14

ENCLOSURE RECOMMENDATION

XTRPRO802 & 804 Vented Enclosure Recommendations

Box Properties

— Description —

Type: Vented Box
Shape: Prism, Square

— Box Parameters —

Vb = 0.75 cu.ft
V(total) = 0.856 cu.ft
Fb = 44 Hz
QL = 7
F3 = 35.24 Hz
Fill = none

— Vents —

No. of Vents = 1
Vent shape = round
Vent ends = one flush
Dv = 3 in. (76 mm)
Lv = 11.19 in. (284 mm)

Figure 15
Figura 15
Abbildung 15

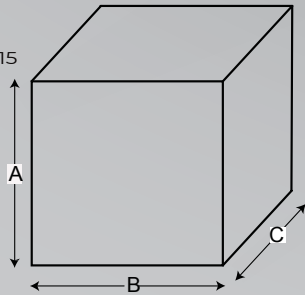

External Dimensions

A = 13.5 in. (343 mm)
B = 13.5 in. (343 mm)
C = 10.5 in. (267 mm)

Internal Dimensions

A = 12 in. (305 mm)
B = 12 in. (305 mm)
C = 9 in. (229 mm)

Wall Thickness

Front = 0.75 in. (19 mm)
Side = 0.75 in. (19 mm)

—Box Parts—

Box Shape: Square Prism

1 Top, 1 Bottom:

depth (c) = 10.5 in. (289 mm)
width (b) = 13.5 in. (343 mm)
thickness = 0.75 in. (19 mm)

1 Front, 1 Back:

height (a) = 12 in. (305 mm)
width (d) = 12 in. (305 mm)
thickness = 0.75 in. (19 mm)

height (a) = 12 in. (267 mm)
depth (c) = 10.5 in. (267 mm)
thickness = 0.75 in. (19 mm)

—Driver Mounting—

Mounting: Front

Vent Parts

1 Duct:

outside diameter (e) = 3 in. (76 mm)
inside diameter (g) = 3 in. (76 mm)
length (h) = 11.19 in. (284 mm)



ENCLOSURE RECOMMENDATION

Enclosure Details

- External dimensions calculated for 3/4" building material
- Includes speaker displacement
- Volumes given are net tuning volume
- Enclosures include a minimal amount of damping material. Just enough material to line the inside of the enclosure is required.

XTRPRO102D & 104D Sealed Enclosure Recommendations

Box Properties

— Description —

Type: Closed Box
Shape: Prism, Square

— Box Parameters —

Vb = 0.75 cu.ft
V(total) = 0.791 cu.ft
Qtc = 0.598
QL = 7
F3 = 50.61 Hz
Fill = none

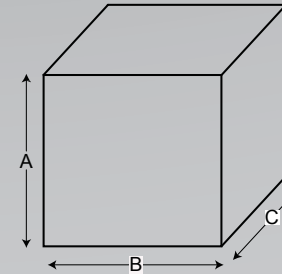

External Dimensions

A = 12 in. (305 mm)
B = 15.5 in. (394 mm)
C = 10.8 in. (274 mm)

Internal Dimensions

A = 10.5 in. (267 mm)
B = 14 in. (356 mm)
C = 9.3 in. (236 mm)

Wall Thickness

Front = 0.75 in. (19 mm)
Side = 0.75 in. (19 mm)

—Box Parts—

Box Shape: Square Prism

1 Top, 1 Bottom:

depth (c) = 10.8 in. (274 mm)
width (b) = 15.5 in. (394 mm)
thickness = 0.75 in. (19 mm)

1 Front, 1 Back:

height (a) = 10.5 in. (267 mm)
width (d) = 14 in. (356 mm)
thickness = 0.75 in. (19 mm)

2 Sides: height (a) = 10.5 in. (267 mm)

depth (c) = 10.8 in. (274 mm)
thickness = 0.75 in. (19 mm)

—Driver Mounting—

Mounting: Front

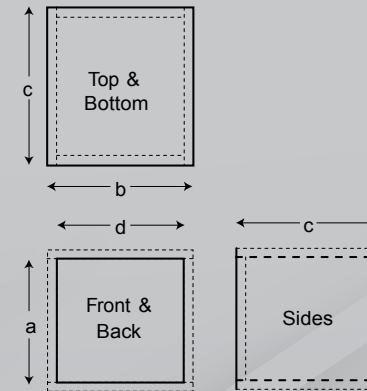

Figure 14
Figura 14
Abbildung 14

ENCLOSURE RECOMMENDATION

XTRPRO102 & 104 Vented Enclosure Recommendations

Box Properties

— Description —

Type: Vented Box

Shape: Prism, Square

— Box Parameters —

Vb = 0.75 cu.ft

V(total) = 0.841 cu.ft

Fb = 44 Hz

QL = 7

F3 = 35.24 Hz

Fill = none

— Vents —

No. of Vents = 1

Vent shape = round

Vent ends = one flush

Dv = 3 in. (76 mm)

Lv = 11.19 in. (284 mm)

Figure 15
Figura 15
Abbildung 15

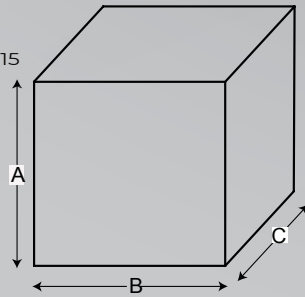

External Dimensions

A = 12 in. (305 mm)

B = 15.5 in. (394 mm)

C = 11.39 in. (289 mm)

Internal Dimensions

A = 10.5 in. (267 mm)

B = 14 in. (356 mm)

C = 9.89 in. (251 mm)

Wall Thickness

Front = 0.75 in. (19 mm)

Side = 0.75 in. (19 mm)

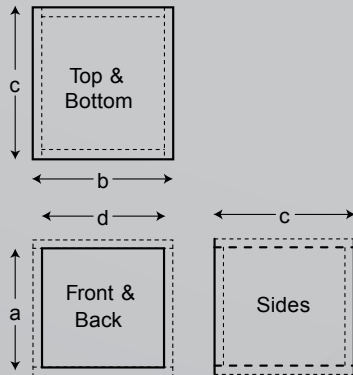

—Box Parts—

Box Shape: Square Prism

1 Top, 1 Bottom:

depth (c) = 11.39 in. (289 mm)

width (b) = 15.5 in. (394 mm)

thickness = 0.75 in. (19 mm)

1 Front, 1 Back:

height (a) = 10.5 in. (267 mm)

width (d) = 14 in. (356 mm)

thickness = 0.75 in. (19 mm)

height (a) = 10.5 in. (267 mm)

depth (c) = 11.39 in. (289 mm)

thickness = 0.75 in. (19 mm)

—Driver Mounting—

Mounting: Front

Vent Parts

1 Duct:

outside diameter (e) = 3.25 in. (83 mm)

inside diameter (g) = 3 in. (76 mm)

length (h) = 11.19 in. (284 mm)



ENCLOSURE RECOMMENDATION

XTRPRO122 & 124 Sealed Enclosure Recommendations

Box Properties

— Description —

Type: Closed Box

Shape: Prism, Square

— Box Parameters —

Vb = 1.5 cu.ft

V(total) = 1.55 cu.ft

Qtc = 0.717

QL = 6.886

F3 = 43.09 Hz

Fill = none

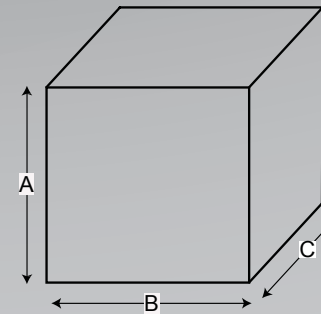

External Dimensions

A = 16 in. (406 mm)

B = 16 in. (406 mm)

C = 14.24 in. (362 mm)

Internal Dimensions

A = 14.5 in. (368 mm)

B = 14.5 in. (368 mm)

C = 12.74 in. (324 mm)

Wall Thickness

Front = 0.75 in. (19 mm)

Side = 0.75 in. (19 mm)

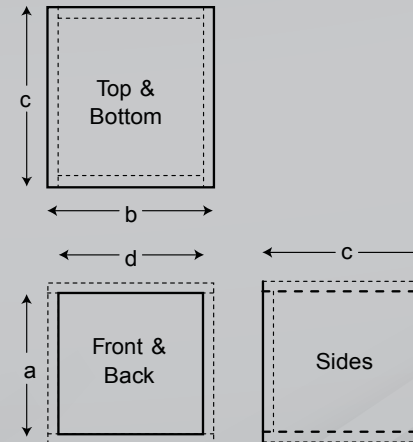

—Box Parts—

Box Shape: Square Prism

1 Top, 1 Bottom:

depth (c) = 14.24 in. (362 mm)

width (b) = 16 in. (406 mm)

thickness = 0.75 in. (19 mm)

1 Front, 1 Back:

height (a) = 14.5 in. (368 mm)

width (d) = 14.5 in. (368 mm)

thickness = 0.75 in. (19 mm)

2 Sides:

height (a) = 14.5 in. (368 mm)

depth (c) = 14.24 in. (362 mm)

thickness = 0.75 in. (19 mm)

—Driver Mounting—

Mounting: Front

Figure 16
Figura 16
Abbildung 16

ENCLOSURE RECOMMENDATION

XTRPRO122 & 124 Vented Enclosure Recommendations

Box Properties

— Description —

Type: Vented Box
Shape: Prism, Square

— Box Parameters — Vb

= 1.5 cu.ft
V(total) = 1.637 cu.ft
Fb = 40 Hz
QL = 6.886
F3 = 32.19 Hz
Fill = none

— Vents —

No. of Vents = 1
Vent shape = round
Vent ends = one flush
Dv = 4 in. (102 mm)
Lv = 11.26 in. (286 mm)

Figure 17
Figura 17
Abbildung 17

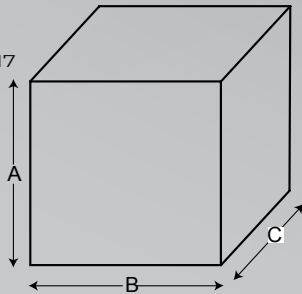

External Dimensions

A = 13.5 in. (343 mm)
B = 18.5 in. (470 mm)
C = 15.36 in. (390 mm)

Internal Dimensions

A = 12 in. (305 mm)
B = 17 in. (432 mm)
C = 13.86 in. (352 mm)

Wall Thickness

Front = 0.75 in. (19 mm)
Side = 0.75 in. (19 mm)

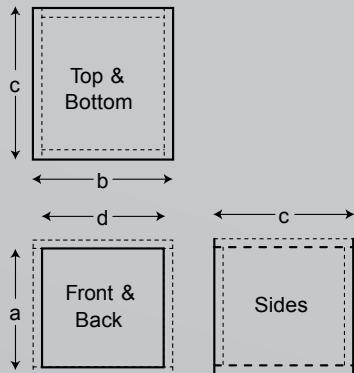

—Box Parts—

Box Shape: Square Prism

1 Top, 1 Bottom:

depth (c) = 15.36 in. (390 mm)
width (b) = 18.5 in. (470 mm)
thickness = 0.75 in. (19 mm)

1 Front, 1 Back:

height (a) = 12 in. (305 mm)
width (d) = 17 in. (432 mm)
thickness = 0.75 in. (19 mm)

height (a) = 12 in. (305 mm)
depth (c) = 15.36 in. (390 mm)
thickness = 0.75 in. (19 mm)

—Driver Mounting—

Mounting: Front

Vent Parts

1 Duct:

outside diameter (e) = 4.25 in. (108 mm)
inside diameter (g) = 4 in. (102 mm)
length (h) = 11.26 in. (286 mm)



ENCLOSURE RECOMMENDATION

XTRPRO152 & 154 Sealed Enclosure Recommendations

Box Properties

— Description —

Type: Closed Box
Shape: Prism, Square

— Box Parameters — Vb

= 2 cu.ft
V(total) = 2.078 cu.ft
Qtc = 0.963
QL = 5.281
F3 = 37.55 Hz
Fill = none

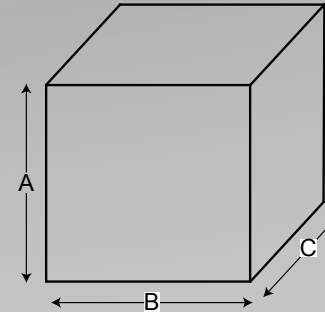

External Dimensions

A = 17.5 in. (445 mm)
B = 17.5 in. (445 mm)
C = 15.52 in. (394 mm)

Internal Dimensions

A = 16 in. (406 mm)
B = 16 in. (406 mm)
C = 14.02 in. (356 mm)

Wall Thickness

Front = 0.75 in. (19 mm)
Side = 0.75 in. (19 mm)

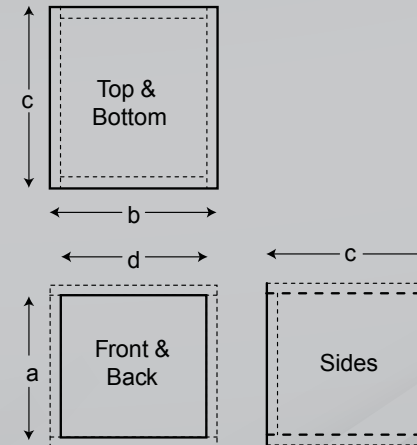

—Box Parts—

Box Shape: Square Prism

1 Top, 1 Bottom:

depth (c) = 15.52 in. (394 mm)
width (b) = 17.5 in. (445 mm)
thickness = 0.75 in. (19 mm)

1 Front, 1 Back:

height (a) = 16 in. (406 mm)
width (d) = 16 in. (406 mm)
thickness = 0.75 in. (19 mm)

2 Sides:

height (a) = 16 in. (406 mm)
depth (c) = 15.52 in. (394 mm)
thickness = 0.75 in. (19 mm)

—Driver Mounting—

Mounting: Front

Figure 18
Figura 18
Abbildung 18

XTRPRO152 & 154 Vented Enclosure Recommendations

Box Properties

— Description —	— Box Parameters — Vb	— Vents —	
Type: Vented Box	= 3 cu.ft	No. of Vents	= 1
Shape: Prism, Square	V(total) = 3.116 cu.ft	Vent shape	= round
	Fb = 36 Hz	Vent ends	= one flush
	QL = 5	Dv	= 4 in. (102 mm)
	F3 = 29.7 Hz	Lv	= 5.422 in. (138 mm)
	Fill = none		

Figure 19
Figura 19
Abbildung 19

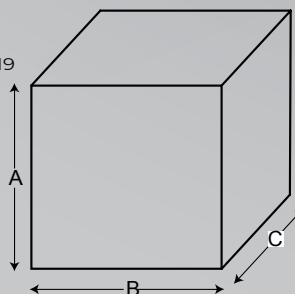

External Dimensions

A = 18.5 in. (470 mm)
B = 23.5 in. (597 mm)
C = 15.9 in. (404 mm)

Internal Dimensions

A = 17 in. (432 mm)
B = 22 in. (559 mm)
C = 14.4 in. (366 mm)

Wall Thickness

Front = 0.75 in. (19 mm)
Side = 0.75 in. (19 mm)

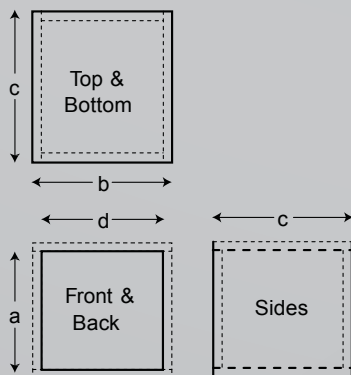

—Box Parts—

Box Shape: Square Prism

1 Top, 1 Bottom:

depth (c) = 15.9 in. (404 mm)
width (b) = 23.5 in. (597 mm)
thickness = 0.75 in. (19 mm)

1 Front, 1 Back:

height (a) = 17 in. (432 mm)
width (d) = 22 in. (559 mm)
thickness = 0.75 in. (19 mm)

height (a) = 17 in. (432 mm)
depth (c) = 15.9 in. (404 mm)
thickness = 0.75 in. (19 mm)

—Driver Mounting—

Mounting: Front

Vent Parts --- Square

1 Duct:

outside diameter (e) = 4.25 in. (108 mm)
inside diameter (g) = 4 in. (102 mm)
length (h) = 5.422 in. (138 mm)



Investigate the layout of your vehicle thoroughly before drilling or cutting. Take care when you work near the gas tank, gas lines, hydraulic lines, electrical components and electrical wiring. Do not use the equipment unmounted. Attach this system securely to prevent damage, particularly in the event of an accident or aggressive driving. Do not mount the system so that wire connections are unprotected or are subjected to pinching or damage from nearby objects. Before connecting or disconnecting power connections at the system power terminals, disconnect the +12V DC wire at the battery end. Confirm that your source unit and other equipment are turned off while connecting the input terminals. If you need to replace the power fuse, replace it only with a fuse identical to the amperage recommended. Using a fuse of different type or rating may result in damage to the system, which is not covered by the manufacturer's warranty. Do not install any product where it may be subjected to excessive heat, moisture and dust or where it may be repeatedly kicked, brushed or bumped. Make absolutely sure that the terminals for the products are connected to the proper inputs and outputs from the music source. Never run the wiring on the outside of the vehicle or under it where it can be damaged by road hazards or any moving parts of the vehicle. Use existing wire channels, sills, panels and molding strips inside the vehicle to hide the wiring for safety and a neat appearance.

DISCLAIMER

IMPORTANT: Never cut any metal that is an integral part of the vehicle's safety or structural support system. If you are unsure, it is best to have the product professionally installed by an Authorized ORION Dealer. Never sacrifice your safety for sound.

Symptom	Check Point	Remedy
No Sound	Is the amplifier power LED illuminated?	1. Check fuses in amplifier 2. Check turn-on lead 3. Check signal lead 4. Check gain control 5. Check source unit volume 6. Clean contacts on fuse holders
	Is the amplifier overload LED illuminated?	Check speaker for short or amplifier for overheating
	Check impedance with Ohm meter	If no reading, replace speaker
	Check that the speaker moves freely	If speaker won't move, replace speaker
Speaker is making a rattling noise	Check that speaker is secured properly and tightened with screws	Tighten mounting screws
	Check enclosure construction	Check that the enclosure is debris free
	Check speaker polarity	Correct polarity
No sound from one coil	Check speaker leads	1. Inspect for short circuits 2. Check for open connections Reverse left and right speaker leads to determine if it is occurring before the speaker
Speaker is distorting at high volume levels	Check speaker load impedance capabilities for the amplifier	Confirm that the speaker load impedance recommendations are followed. Check the wiring configuration of the speaker. (To verify proper load impedance, use an OHM meter to measure the total load for each channel of the amplifier.)
	Verify that amplifier and/or crossover settings are correct	Select low-pass setting

Orion warrants this product against all defects in material and workmanship for a period of one (1) year from the date of original purchase provided it was purchased from an Authorized Orion Dealer.

The conditions of this warranty and the extent of the responsibility of Orion, under this warranty are as follows:

1. DATED PROOF OF PURCHASE IS REQUIRED FOR WARRANTY SERVICE OF THIS PRODUCT. Information about Orion authorized warranty service may also be obtained at www.orioncaraudio.com or by emailing Orion at support@orioncaraudio.com.
2. This warranty will become void if service is performed by anyone other than an approved Orion Warranty Service Center.
3. This warranty does not apply to any product which has been subjected to misuse, neglect or accident, or which has had the warranty seal broken, serial number altered, defaced or removed, or which has been connected, installed adjusted or repaired other than in accordance with the instructions furnished by Orion.
4. This warranty does not cover car static, electrical interference, adjustments or labor costs for the removal or reinstallation of the unit for repair.
5. The sole responsibility of Orion under this warranty shall be limited to the repair or replacement thereof, at the sole discretion of Orion.
6. If it becomes necessary to send the product or any defective part to Orion or an authorized service station, the product must be shipped in its original or equivalent carton, fully insured, with shipping charges prepaid. Orion will not assume any responsibility for any loss or damage incurred in shipping.
7. This warranty is not transferable and protects the original purchaser provided they reside and made their purchase in the United States. International consumers may contact their local retailer or distributor for warranty information.
8. ALL IMPLIED WARRANTIES, EXCEPT TO THE EXTENT PROHIBITED BY APPLICABLE LAW, SHALL HAVE NO GREATER DURATION THAN THE WARRANTY PERIOD SET FORTH ABOVE. UNDER NO CIRCUMSTANCES SHALL ORION BE LIABLE FOR ANY LOSS OR DAMAGE, DIRECT OR CONSEQUENTIAL, ARISING OUT OF THE USE OR INABILITY TO USE THE PRODUCT BECAUSE SOME STATES DO NOT ALLOW LIMITATIONS ON HOW LONG AN IMPLIED WARRANTY LASTS OR EXCLUSIONS OR LIMITATIONS OF INCIDENTAL OR CONSEQUENTIAL DAMAGES, THE ABOVE LIMITATIONS OR EXCLUSIONS MAY NOT APPLY TO YOU.
9. THIS WARRANTY GIVES YOU SPECIFIC LEGAL RIGHTS AND YOU MAY ALSO HAVE OTHER RIGHTS THAT VARY FROM STATE TO STATE.
10. Should you have any difficulties with the performance of this product during warranty or with any Orion authorized service center, you may contact Orion by emailing us at support@orioncaraudio.com.

ORION

3130 WEST 15TH AVENUE HIALEAH, FLORIDA 33012

TEL: 786.464.0247 EMAIL: SUPPORT@ORIONCARAUDIO.COM ORIONCARAUDIO.COM

PROUD SPONSOR OF



Copyright ORION

All rights reserved. Any unauthorized reproduction or use of any Orion logos, images or design elements is strictly prohibited by law. Specifications subject to change without notice. REV. 26.2