

 **ORION**TM
HIGH PERFORMANCE CAR AUDIO

HCCATM
COMPETITION

HCCA802	HCCA804
HCCA102	HCCA104
HCCA122	HCCA124
HCCA152	HCCA154

BLACK COIL
S E R I E S

**HIGH PERFORMANCE
COMPETITION SUBWOOFERS**

proud to be LOUD!

Thank you for purchasing this Orion product. Orion products are specifically engineered and designed for the mobile audio environment. This manual contains important information about installation, set-up procedures and integrating your new Orion product into your vehicle. With proper care and installation, your new product will provide you with many years of high performance listening enjoyment. We recommend having an Authorized Orion Dealer install your new product for optimal performance. Before installing your new product, please read through the manual to fully understand the application.

Before making any electrical connections, make sure that you disconnect the battery's ground cable to prevent the possibility of short circuits or damage to your electronic equipment. If your vehicle's stereo (head unit) comes with an Anti-theft code, DO NOT disconnect the battery. If you have the access code for the stereo (head unit), please refer to the vehicle's owner's manual.

ATTENTION

FOR ANY QUESTIONS, ISSUES, RETURNS OR WARRANTY

DO NOT contact the retailer, we recommend that you contact our service department for any and all assistance at support@orioncaraudio.com.

We will do our best to resolve any problem in a professional and timely manner.

INTRODUCTION.....	2
FEATURES.....	3
SPECIFICATION.....	4-5
WIRING CONFIGURATION.....	6-12
BUILDING AN ENCLOSURE.....	13
ENCLOSURE DETAILS.....	14
ENCLOSURE RECOMMENDATION.....	15-28
WARNING & DISCLAIMER.....	29
TROUBLESHOOTING.....	30
WARRANTY.....	31-32

WHAT'S IN THE BOX

- 1 x HCCA Subwoofer
- 1 x Mounting Template
- 1 x Owner's Manual
- 1 x Window Sticker



WARNING: This product can expose you to chemicals including DEHP which is known to the State of California to cause cancer, birth defects or other reproduction harm. For more information go to www.P65warnings.ca.gov.

FEATURES

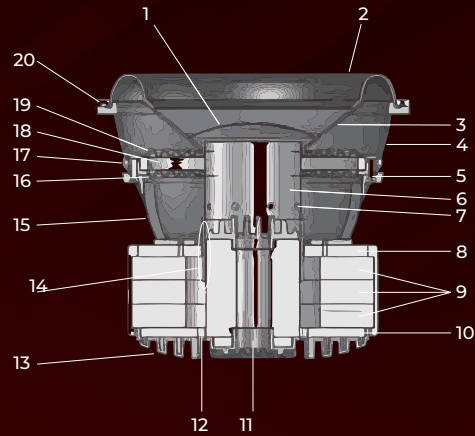

1	Polypropylene dust cap - moisture and UV resistant.
2	Tall, wide, balanced, NBR Foam (high density expanded polyester foam) surround for linear controlled long excursion using a Tri Radius symmetrical edge design optimized on non-linear FEA.
3	Paper cone - moisture and UV resistant.
4	Custom Cast Aluminum frame.
5	Spider ring attachment screws. Part of re-cone feature (8 hex screws)
6	aluminum voice coil former (8" uses 2.5" voice coil former, 10" uses 3" voice coil former, 12 & 15 use a 4" voice coil former)
7	Venting in Voice coil former. Part of the enhanced voice coil cooling system (forced convection)
8	11mm Steel front plate.
9	Large 3 stack ceramic magnets (8", 174 oz, 10" 264 oz, 12/15" 445 oz)
10	11mm Steel back plate/pole piece T yoke assembly
11	1.25" vent. Part of the enhanced voice coil cooling system (forced convection - aluminum heat sinking - shorting rings to reduce inductive heating)..
12	Voice coil gap vents. Part of the enhanced voice coil cooling system (forced convection - aluminum heat sinking -shorting rings to reduce inductive heating).
13	Cast aluminum rear pole piece heat sink with fins and vent holes. Part of the enhanced voice coil cooling system (forced convection - aluminum heat sinking)
14	High temperature (Polyester Amide Resin Coated) Copper clad Aluminum voice coil wound on an aluminum former (8" uses 2.5" voice coil, 10" uses 3" voice coil, 12 & 15 use a 4" voice coil) Dual 2 and 4 ohm voice coils available
15	Screen meshed areas to allow venting below spider to and keep foreign object out of the voice coil gap.
16	Bottom flat interlaced Conex spider with stitched and looped tinsel leads attached.
17	Custom allen head screw terminals. A pair on each side (one pair for each voice coil).
18	Spider spacer and spider mounting ring assembly part of field re-cone kit attachment method. (eight allen head screws).
19	Top flat interlaced Conex spider.
20	Surround clamp ring, part of field re-cone kit attachment method. (eight allen head screws).

SPECIFICATIONS

Model Number	HCCA802	HCCA804	HCCA102	HCCA104	HCCA122	HCCA124	HCCA152	HCCA154
Size	8"	8"	10"	10"	12"	12"	15"	15"
Fs (free-air resonance, Hz)	58	57.8	42.51	44.3	32.3	33.2	28.13	30.02
Vas (equivalent compliance, cu. ft.)	0.17	0.16	0.31029	0.31699	0.89274	0.93157	2.95746	2.82259
Vas (equivalent compliance, liters)	4.72	4.5	8.79	8.98	25.29	26.39	83.78	79.96
Qms (Q, mechanical)	4.82	4.77	7.16	5.99	5.08	4.16	5.17	4.38
Qes (Q, electrical)	0.56	0.63	0.48	0.52	0.5	0.54	0.55	0.61
Qts (total driver Q)	0.5	0.55	0.45	0.48	0.45	0.48	0.5	0.54
Re (DC resistance, ohms)	3.73	7.42	3.9	7.4	4	7.4	4	7.3
Z (nominal impedance, ohms)	2x2	4x2	2x2	4x2	2x2	4x2	2x2	2x2
Le (inductance, mh)	2.1	2.3	1.93	2.93	2.61	3.67	2.59	3.68
Efficiency (1W @ 1M, db)	84.13	83.75	86.51	83.66	84.22	83.38	87.2	87.4
Xmas (one way linear excursion, in.)	0.77	0.77	1.01948	1.01948	1.18939	1.18939	1.18939	1.18939
Xmas (one way linear excursion, mm)	19.6	19.6	25.89	25.89	30.1875	30.18	30.18	30.18
RMS POWER WATTS	1500	1500	2000	2000	2500	2500	2500	2500
NOMINAL POWER WATTS	3000	3000	4000	4000	5000	5000	5000	5000
MAX MUSIC POWER WATTS	6000	6000	8000	8000	10000	10000	10000	10000
Mms (total moving mass, grams)	174	171	250	225	425	386	500	460
Cms (mechanical compliance, m/N)	0.048	0.045	0.000056	0.000057	0.000057	0.00006	0.00005	0.000061
Bl (motor strength, Tesla-M)	20.6	27	23.3	29.86	26.27	33.2	25.34	32.21
Sd (effective radiating area, sq. cm.)	268.8	268.8	333.29	333.29	559.9	559.9	962.11	962.11
Sd (effective radiating area, sq. in.)	41.66	41.66	51.66	51.66	86.78	86.78	149.13	149.13
Frequency Range (Hz)	35-150	35-150	32-100	33-100	24-100	25-100	21-100	22-100
Energy Bandwidth Product (EBP)**	104	92	89	85	65	61	51	49

SPECIFICATIONS

Model Number	HCCA802	HCCA804	HCCA102	HCCA104
Physical Dimensions				
Speaker Displacement (cu ft)	0.07	0.07	0.1268	0.1268
Speaker Outer Diameter (inches/mm)	9.8/249	9.8/249	9.37/238	9.37/238
Mounting hole diameter (inches/mm)	8.07/205	8.07/205	9.37/238	9.37/238
Mounting depth (inches/mm)	7.56/191.9	7.56/191.9	8.425/214	8.425/214
Magnet Weight (Oz)	174	174	263.7	263.7
Recommended Enclosures				
Typical sealed enclosure (cu. ft.)	0.3	0.3	0.9	0.9
Vented enclosure (cu. ft.) ***	0.65	0.65	0.75	0.75
Port tuning frequency (Hz)	40	40	42	42
Port square equivalent (inches)	2x8	2x8	2.5x2.5	2.5x2.5
Port length (inches)	11.5	11.5	10.95	10.95

Model Number	HCCA122	HCCA124	HCCA152	HCCA154
Physical Dimensions				
Speaker Displacement (cu ft)	0.28931	0.28931	0.37704	0.37704
Speaker Outer Diameter (inches/mm)	292	292	383	383
Mounting hole diameter (inches/mm)	11.5	11.5	15.079	15.079
Mounting depth (inches/mm)	10.28/261	10.28/261	11.575/294	11.575/294
Magnet Weight (Oz)	444.98	444.98	444.98	444.98
Recommended Enclosures				
Typical sealed enclosure (cu. ft.)	2	2	3.64	3.64
Vented enclosure (cu. ft.) ***	1.5	1.5	3.05	3.05
Port tuning frequency (Hz)	40	40	38	38
Port square equivalent (inches)	14x2	14x2	16x3	16x3
Port length (inches)	30.33	31.33	26.62	26.62

WIRING CONFIGURATION

RE-CONE KIT

A re-cone kit is available for these speakers and can be obtained from your dealer. The part number for each model is listed below.

Model/Part#	Description
HCCA802 (RK)	ORION HCCA 8" 2 OHM Re-Cone Kit
HCCA804 (RK)	ORION HCCA 8" 4 OHM Re-Cone Kit
HCCA102 (RK)	ORION HCCA 10" 2 OHM Re-Cone Kit
HCCA104 (RK)	ORION HCCA 10" 4 OHM Re-Cone Kit
HCCA122 (RK)	ORION HCCA 12" 2 OHM Re-Cone Kit
HCCA124 (RK)	ORION HCCA 12" 4 OHM Re-Cone Kit
HCCA152 (RK)	ORION HCCA 15" 2 OHM Re-Cone Kit
HCCA154 (RK)	ORION HCCA 15" 4 OHM Re-cone Kit

WIRING CONFIGURATIONS

The following illustrations provide guidelines on properly connecting your HCCA Orion woofer to an amplifier for maximum power and performance using common parallel, and series/parallel wiring configurations.

Recommended Amplifier Power	
1 woofer	1,200 to 4,000 Watts
2 woofer	2,400 to 8,000 Watts
3 woofer	3,600 to 12,000 Watts
4 woofer	4,800 to 16,000 Watts

WIRING CONFIGURATION



Series - One Speakers (Dual 2 ohm voice coils)

One dual 2 ohm voice coil woofer with voice coils in connected in series results in a 4 ohm load to the amplifier.



Parallel - One Speakers (Dual 2 ohm voice coils)

One dual 2 ohm voice coil woofer with voice coils in parallel results in a 1 ohm load to the amplifier.



WIRING CONFIGURATION



Parallel - One Speakers (Dual 4 ohm voice coils)

One dual 4 ohm voice coil woofer with voice coils in parallel results in a 2 ohm load to the amplifier.



Parallel - Two Speakers (Dual 4 ohm voice coils)

Two dual 4 oh voice woofers with voice coils in parallel results in a 1 ohm to the amplifier.



WIRING CONFIGURATION

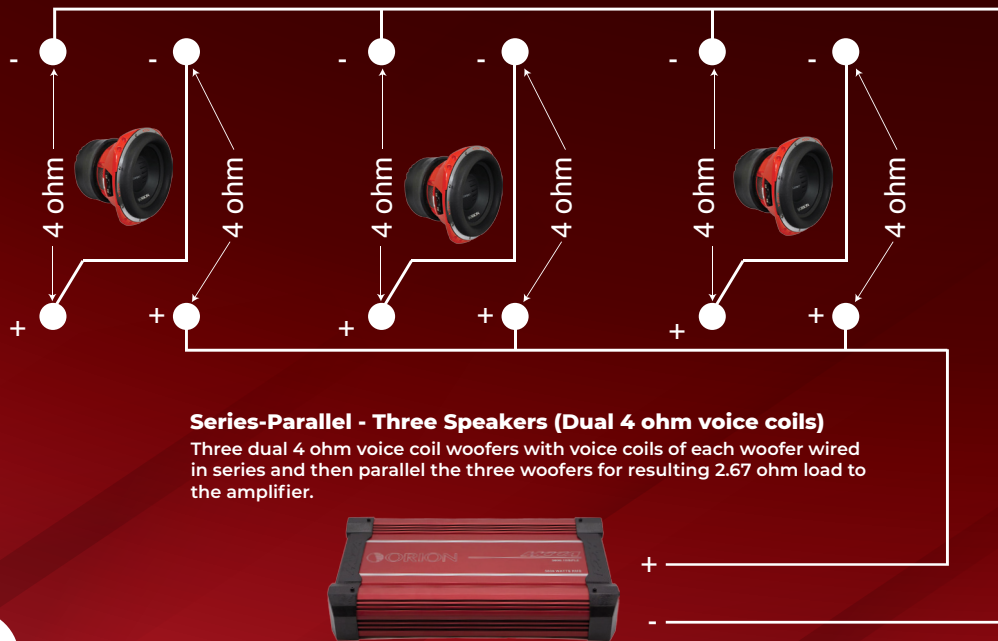
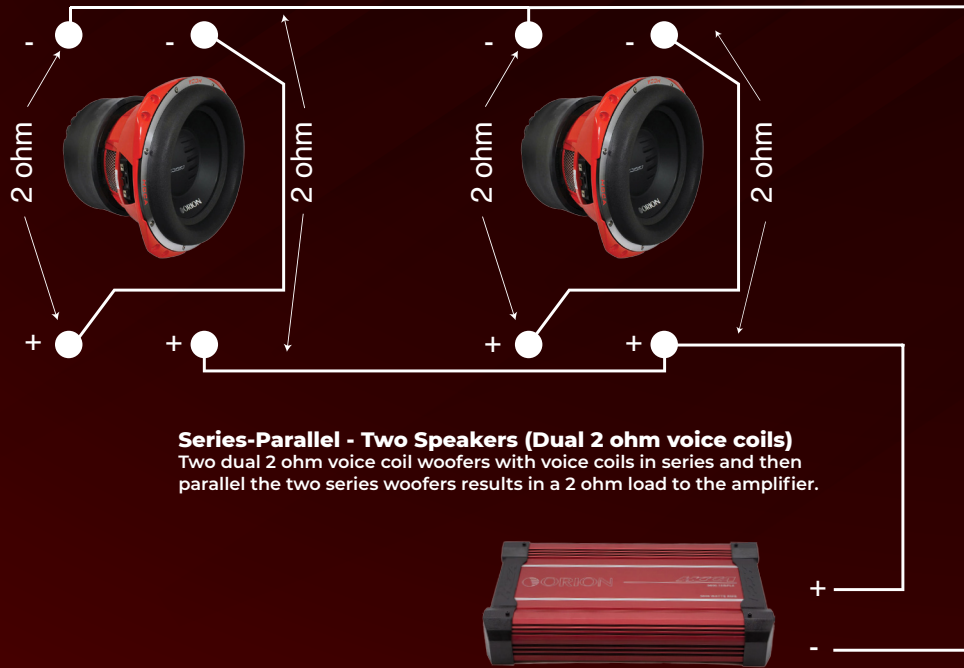

WIRING CONFIGURATION

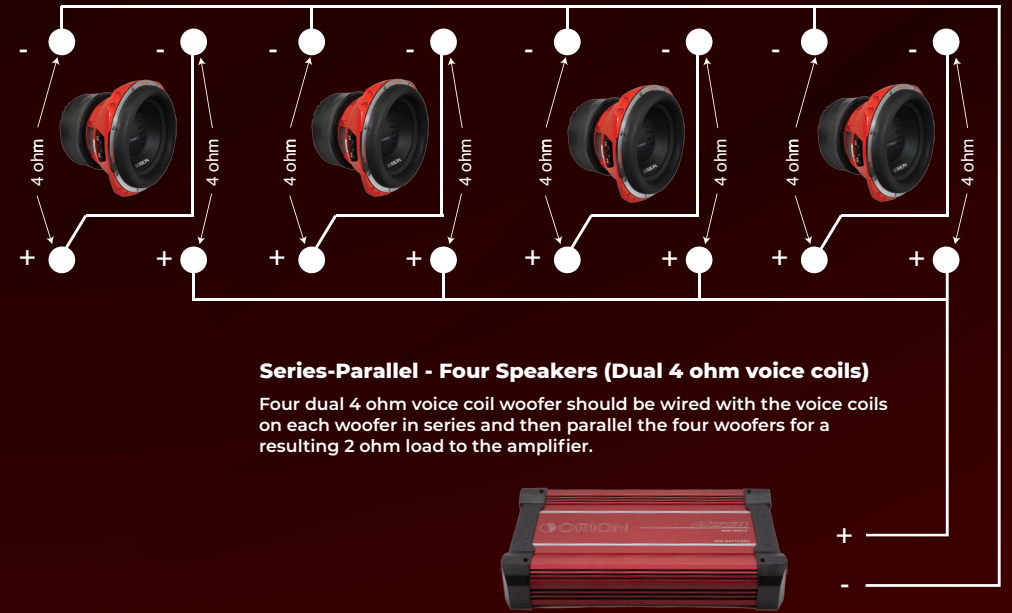

WIRING CONFIGURATION

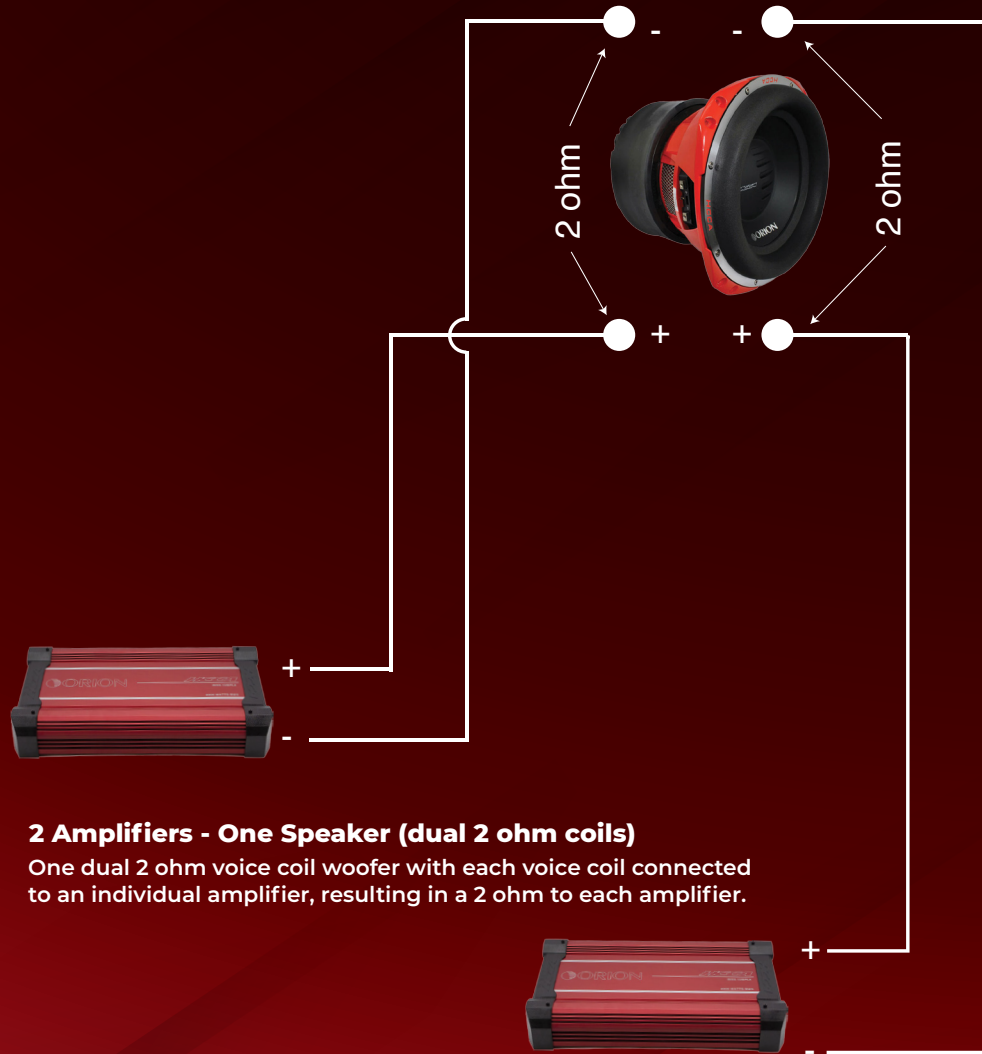

2 Amplifiers - One Speaker (dual 2 ohm coils)

One dual 2 ohm voice coil woofer with each voice coil connected to an individual amplifier, resulting in a 2 ohm to each amplifier.

WIRING CONFIGURATION

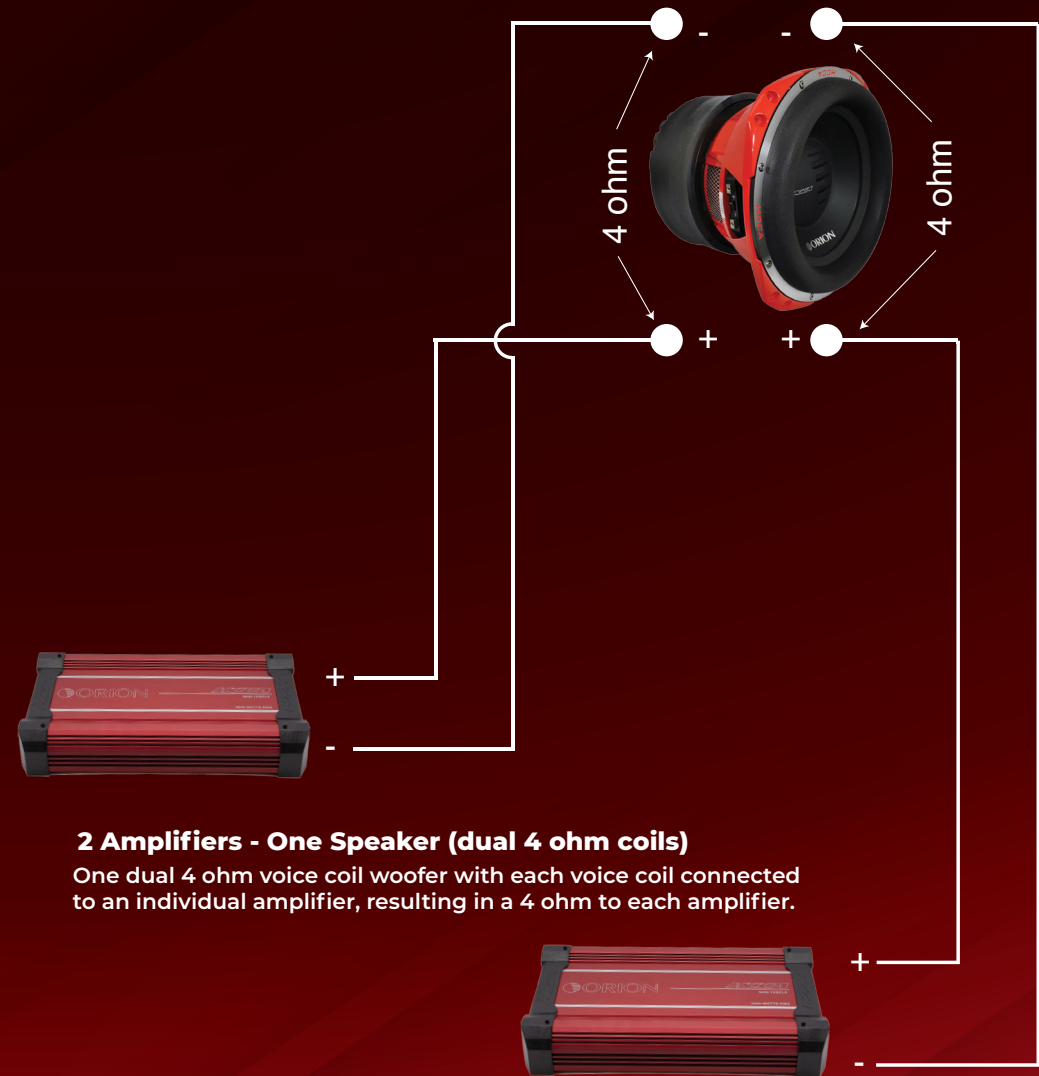

2 Amplifiers - One Speaker (dual 4 ohm coils)

One dual 4 ohm voice coil woofer with each voice coil connected to an individual amplifier, resulting in a 4 ohm to each amplifier.

If you're planning to build your own enclosure and are confused in what type of enclosure best suits your needs this page will help you choose what enclosure best fits your needs. There are many different types of enclosures. The two most common used enclosures are sealed and vented enclosure. This page will show the advantages and disadvantages of the two enclosures.

ADVANTAGES OF A SEALED ENCLOSURES

- High power handling capability
- Great transient response
- Tolerant of minor enclosure size variation
- Easy to construct
- Smooth roll off (12dB/octave)

DISADVANTAGES OF A SEALED ENCLOSURES

- Requires a woofer with a long excursion for better low bass frequency response.
- Can have lower sensitivity than ported enclosures.
- When using high power and small enclosures, the woofer is not in an ideal cooling environment.
- Lower bass as compared to a properly tuned vented enclosure above the ported tuning frequency.

ADVANTAGES OF A VENTED ENCLOSURE

- Increased output around vented tuning
- Higher power handling above the port tuning frequency
- Extended frequency response
- Magnet is in a good cooling environment
- Handles higher bass frequencies with less distortion

DISADVANTAGES OF A VENTED ENCLOSURE

- Vented enclosure transient response is not as good as sealed boxes because of the resonant effect of the vent tuning
- Midrange sound coming from inside the enclosure through the vent can produce unpleasant sound coloration.
- Loss of cone movement control below vent tuning, which can result in high distortion and mechanical failure of the driver.
- Lower power handling below the port tuning frequency

ENCLOSURE DETAILS

1. Parameters listed are for conventional applications only, for further help please call Sound Pros Tech Support.
2. At least 0.75" MDF (Medium Density Fiberboard) is recommended for any enclosure.
3. Recommended enclosures are NET box volumes, speaker and port displacement are calculated into the volume of the enclosure, you will need to add these volumes to calculate GROSS volume for the enclosure.

NOTES

- * Due to the high power capabilities and long excursion of the HCCA woofers, the Thiele/Small Parameters were calculated and measured using Klippel analyzer system.
- ** Energy Bandwidth Product (EBP) is determined by the following formula $F_s/Q_{es}=EBP$. EBP values of 50 and lower suggest a sealed enclosure is best, 50 to 90 means the subwoofer versatile and 90 and above mean vented Enclosure is recommended.
- *** Subsonic filter should always be used and adjusted specifically for vented box designs.

ENCLOSURE DESIGN

This section gives the basic description for a sealed enclosure. Orion HCCA woofers are designed for sealed enclosures and vented enclosures. Sealed enclosures are generally considered the most versatile for all music types and are the easiest to build. They will also give high power handling with a wider range of frequencies. The enclosure must be absolutely air tight. Use a high quality wood glue for all seams of the enclosure. The enclosure should also be screwed together. The enclosure should be no less than 3/4" on sides. The baffle board (woofer mounting plate) should be no less than 1". If the woofer mounting is to be recessed then a minimum of two 3/4" plates together should be used. As MDF is a porous material it is best to also seal the inside of the enclosure.

NOTE: The woofer must face up or down only, specially in sealed enclosures.

NOTE: Refer to the website www.orioncaraudio.com for updated enclosure data for your woofer application.

HCCA802 & HCCA804 SEALED ENCLOSURE

Box Properties

— Description —

Type: Closed Box
Shape: Prism, Square

— Box Parameters —

V_b = 0.30 cu.ft
V(total) = 0.40 cu.ft
Q_{tc} = 0.75
QL = 20
F3 = 58 Hz
Fill = Light polyfill (optional)

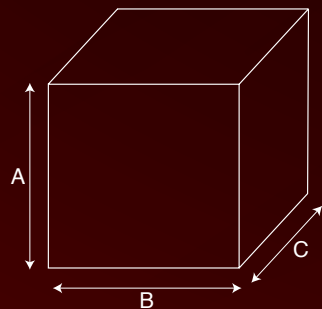

— External Dimensions —

A = 10.75 in. (273.1 mm)
B = 10.75 in. (273.1 mm)
C = 11 in. (279.4 mm)

— Internal Dimensions —

A = 8.75 in. (222.2 mm)
B = 8.75 in. (222.2 mm)
C = 9 in. (228.6 mm)

— Wall Thickness —

Front = 1 in. (25.4mm)
Sides = 1 in. (25.4mm)

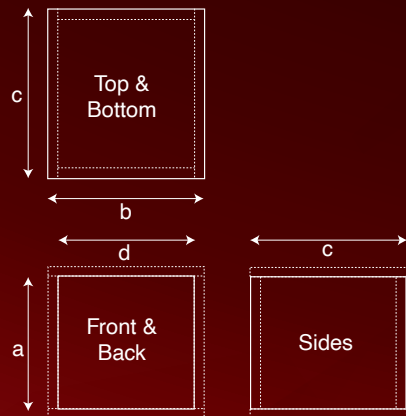

— Box Parts —

Box Shape – Square Prism

1 Top, 1 Bottom

depth (c) = 10.75 in. (273.1 mm)
width (b) = 11 in. (279.4 mm)
thickness = 1.0 in. (25.4mm)

1 Front, 1 Back

height (a) = 10.75 in. (273.1 mm)
width (d) = 10.75 in. (273.1 mm)
thickness = 1.0 in. (25.4mm)

2 Sides

height (a) = 11 in. (279.4 mm)
depth (c) = 10.75 in. (273.1 mm)
thickness = 1.0 in. (25.4mm)

— Driver Mounting —

Mounting: Front

HCCA802 & HCCA804 VENTED ENCLOSURE

Box Properties

— Description —

Type: Vented Box
Shape: Prism, Square

— Box Parameters —

V_b = 0.65 cu.ft
V(total) = 0.85 cu.ft
F_b = 40 Hz
QL = 7
F3 = 36 Hz
Fill = none

— Vents —

No. of Vents = 1
Vent shape = rectangle
Vent ends = one flush
H_v = 2 in. (50.8 mm)
W_v = 8 in. (203.2 mm)
L_v = 11.50 in. (292.1 mm)

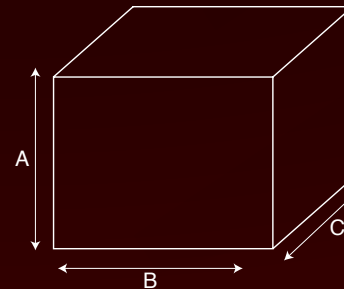

— External Dimensions —

A = 12 in. (304.8 mm)
B = 12 in. (304.8 mm)
C = 16.70 in. (424.2 mm)

— Internal Dimensions —

A = 10 in. (254 mm)
B = 10 in. (254 mm)
C = 14.7 in. (373.4 mm)

— Wall Thickness —

Front = 1 in. (25.4mm)
Sides = 1 in. (25.4mm)

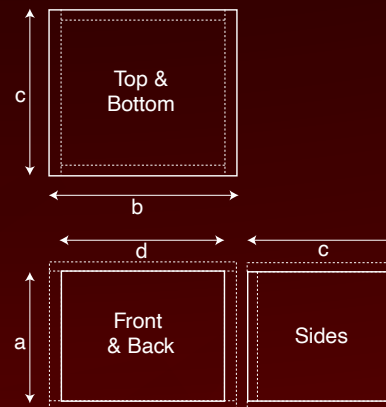

— Box Parts —

Box Shape – Square Prism

1 Top, 1 Bottom

depth (c) = 12 in. (304.8 mm)
width (b) = 16.7 in. (424.2 mm)
thickness = 1 in. (25.4mm)

1 Front, 1 Back

height (a) = 12 in. (304.8 mm)
width (d) = 12 in. (304.8 mm)
thickness = 1 in. (25.4mm)

2 Sides

height (a) = 16.7 in. (424.2 mm)
depth (c) = 12 in. (304.8 mm)
thickness = 1 in. (25.4mm)

— Driver Mounting —

Mounting: Front

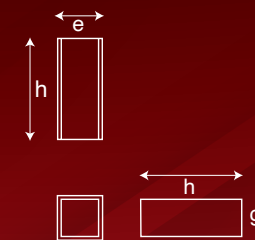

— Vent Parts —

1 Top, 1 Bottom

width (e) = 11.5 in. (292.1 mm)
length (h) = 2 in. (50.8 mm)
thickness = 0.75 in. (19 mm)

2 Sides

height (g) = 11.5 in. (292.1 mm)
length (h) = 8 in. (203.2 mm)
thickness = 0.75 in. (19 mm)

HCCA102 & HCCA104 SEALED ENCLOSURE

Box Properties

— Description —
 Type: Closed Box
 Shape: Prism, Square

— Box Parameters —
 Vb = 0.913 cu.ft
 V(total) = 1 cu.ft
 Qtc = 0.537
 QL = 20
 F3 = 67.85 Hz
 Fill = none

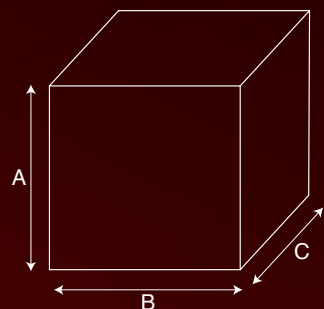

— External Dimensions —
 A = 14 in. (356 mm)
 B = 14 in. (356 mm)
 C = 14 in. (356 mm)
 — Internal Dimensions —
 A = 12 in. (305 mm)
 B = 12 in. (305 mm)
 C = 12 in. (305 mm)
 — Wall Thickness —
 Front = 1 in. (25.4mm)
 Sides = 1 in. (25.4mm)

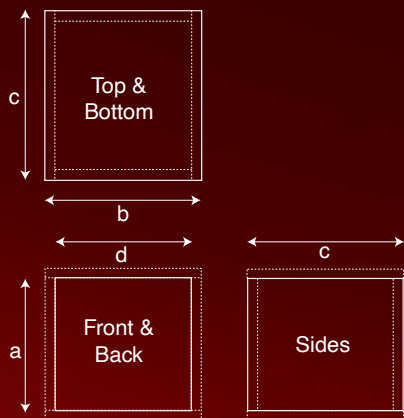

— Box Parts —
 Box Shape — Square Prism
 1 Top, 1 Bottom
 depth (c) = 14 in. (356 mm)
 width (b) = 14 in. (356 mm)
 thickness = 1.0 in. (25.4mm)
 1 Front, 1 Back
 height (a) = 12 in. (305 mm)
 width (d) = 12 in. (305 mm)
 thickness = 1.0 in. (25.4mm)
 2 Sides
 height (a) = 12 in. (305 mm)
 depth (c) = 14 in. (356 mm)
 thickness = 1.0 in. (25.4mm)

— Driver Mounting —
 Mounting: Front

HCCA102 & HCCA104 VENTED 800 TO 1500 WATTS INPUT

Box Properties

— Description —
 Type: Vented Box
 Shape: Prism, Square

— Box Parameters —
 Vb = 1.785 cu.ft
 V(total) = 2.042 cu.ft
 Fb = 38 Hz
 QL = 7
 F3 = 32.05 Hz
 Fill = none

— Vents —
 No. of Vents = 1
 Vent shape = rectangle
 Vent ends = one flush
 Hv = 3.75 in. (95 mm)
 Wv = 3.75 in. (95 mm)
 Lv = 11.67 in. (296 mm)

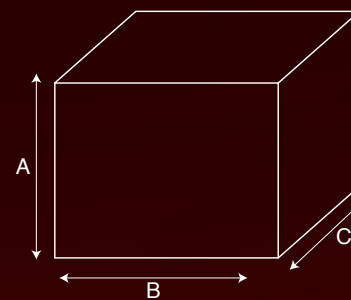

— External Dimensions —
 A = 16 in. (406 mm)
 B = 20 in. (508 mm)
 C = 16 in. (406 mm)
 — Internal Dimensions —
 A = 14 in.
 B = 18 in. (457 mm)
 C = 14 in. (356 mm)
 — Wall Thickness —
 Front = 1 in. (25.4mm)
 Sides = 1 in. (25.4mm)

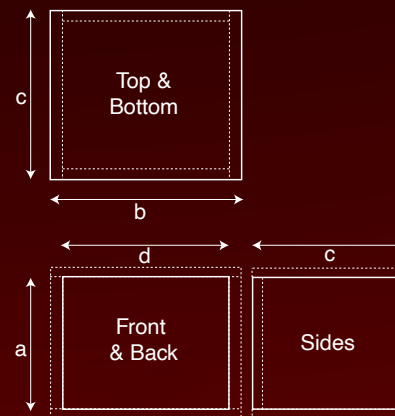

— Box Parts —
 Box Shape — Square Prism
 1 Top, 1 Bottom
 depth (c) = 16 in. (406 mm)
 width (b) = 20 in. (508 mm)
 thickness = 1 in. (25.4mm)
 1 Front, 1 Back
 height (a) = 14 in. (356 mm)
 width (d) = 18 in. (457 mm)
 thickness = 1 in. (25.4mm)
 2 Sides
 height (a) = 14 in. (356 mm)
 depth (c) = 16 in. (406 mm)
 thickness = 1 in. (25.4mm)

— Driver Mounting —
 Mounting: Front

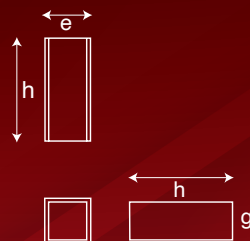

— Vent Parts —
 1 Top, 1 Bottom
 width (e) = 5.25 in. (133 mm)
 length (h) = 11.67 in. (296 mm)
 thickness = 0.75 in. (19 mm)
 2 Sides
 height (g) = 3.75 in. (95 mm)
 length (h) = 11.67 in. (296 mm)
 thickness = 0.75 in. (19 mm)

ENCLOSURE RECOMMENDATION

HCCA102 & HCCA104 VENTED 1500+ WATTS INPUT

Box Properties

— Description —

Type: Vented Box
Shape: Prism, Square

— Box Parameters —

Vb = 0.75 cu.ft
V(total) = 1.007 cu.ft
Fb = 42 Hz
QL = 7
F3 = 35.53 Hz
Fill = none

— Vents —

No. of Vents = 1
Vent shape = rectangle
Vent ends = one flush
Hv = 2.5 in. (64 mm)
Wv = 2.5 in. (64 mm)
Lv = 10.95 in. (278 mm)

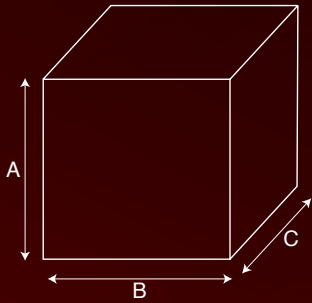

— External Dimensions —

A = 13.5 in. (343 mm)
B = 13.5 in. (343 mm)
C = 15.16 in. (385 mm)

— Internal Dimensions —

A = 11.5 in. (292 mm)
B = 11.5 in. (292 mm)
C = 13.16 in. (334 mm)

— Wall Thickness —

Front = 1 in. (25.4mm)
Sides = 1 in. (25.4mm)

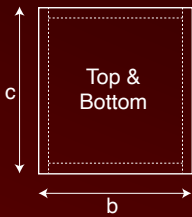

— Box Parts —

Box Shape — Square Prism

1 Top, 1 Bottom

depth (c) = 15.16 in. (385 mm)
width (b) = 13.5 in. (343 mm)
thickness = 1 in. (25.4mm)

1 Front, 1 Back

height (a) = 11.5 in. (292 mm)
width (d) = 11.5 in. (292 mm)
thickness = 1 in. (25.4mm)

2 Sides

height (a) = 11.5 in. (292 mm)
depth (c) = 15.16 in. (385 mm)
thickness = 1 in. (25.4mm)

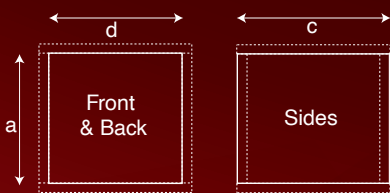

— Driver Mounting —

Mounting: Front

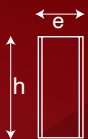

— Vent Parts —

1 Top, 1 Bottom

width (e) = 4 in. (102 mm)
length (h) = 10.95 in. (278 mm)
thickness = 0.75 in. (19 mm)

2 Sides

height (g) = 2.5 in. (64 mm)
length (h) = 10.95 in. (278 mm)
thickness = 0.75 in. (19 mm)

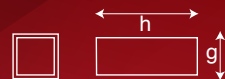

ENCLOSURE RECOMMENDATION

HCCA102 & HCCA104 VENTED SPL ENCLOSURE ONLY

Box Properties

— Description —

Type: Vented Box
Shape: Prism, Square

— Box Parameters —

Vb = 1.25 cu.ft
V(total) = 1.507 cu.ft
Fb = 57 Hz
QL = 7
F3 = 44.65 Hz
Fill = none

— Vents —

No. of Vents = 1
Vent shape = rectangle
Vent ends = one flush
Hv = 4.5 in. (114 mm)
Wv = 4.5 in. (114 mm)
Lv = 9.45 in. (240 mm)

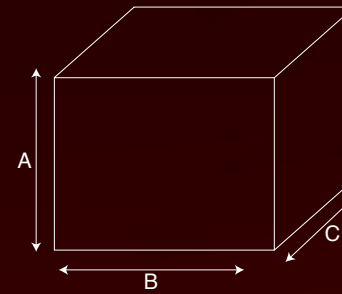

— External Dimensions —

A = 15 in. (381 mm)
B = 15 in. (381 mm)
C = 17.41 in. (442 mm)

— Internal Dimensions —

A = 13 in. (330 mm)
B = 13 in. (330 mm)
C = 15.41 in. (391 mm)

— Wall Thickness —

Front = 1 in. (25.4 mm)
Sides = 1 in. (25.4 mm)

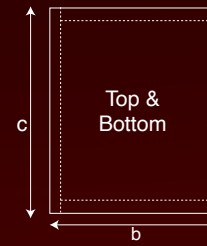

— Box Parts —

Box Shape — Square Prism

1 Top, 1 Bottom

depth (c) = 17.41 in. (442 mm)
width (b) = 15 in. (381 mm)
thickness = 1 in. (25.4 mm)

1 Front, 1 Back

height (a) = 13 in. (330 mm)
width (d) = 13 in. (330 mm)
thickness = 1 in. (25.4 mm)

2 Sides

height (a) = 13 in. (330 mm)
depth (c) = 17.41 in. (442 mm)
thickness = 1 in. (25.4 mm)

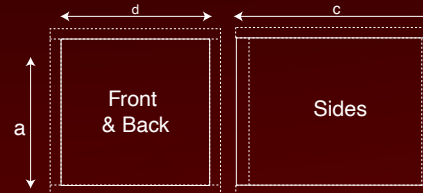

— Driver Mounting —

Mounting: Front

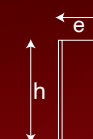

— Vent Parts —

1 Top, 1 Bottom

width (e) = 6 in. (152 mm)
length (h) = 9.45 in. (240 mm)
thickness = 0.75 in. (19 mm)

2 Sides

height (g) = 4.5 in. (114 mm)
length (h) = 9.45 in. (240 mm)
thickness = 0.75 in. (19 mm)



HCCA122 & HCCA124 SEALED ENCLOSURES

Box Properties

— Description —

Type: Closed Box
Shape: Prism, Square (optimum)

— Box Parameters —

Vb = 2 cu.ft
V(total) = 2.244 cu.ft
Qtc = 0.952
QL = 12.95
F3 = 32.93 Hz
Fill = none

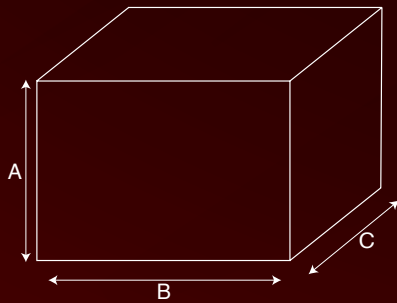

— External Dimensions —

A = 17.71 in. (450 mm)
B = 27.42 in. (697 mm)
C = 11.71 in. (297 mm)

— Internal Dimensions —

A = 15.71 in. (399 mm)
B = 25.42 in. (645.7 mm)
C = 9.709 in. (247 mm)

— Wall Thickness —

Front = 1 in. (25.4 mm)
Sides = 1 in. (25.4 mm)

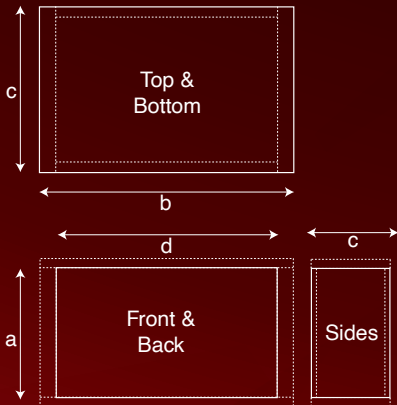

— Box Parts —

Box Shape – Square Prism

1 Top, 1 Bottom

depth (c) = 11.71 in. (297 mm)
width (b) = 27.42 in. (697 mm)
thickness = 1 in. (25.4 mm)

1 Front, 1 Back

height (a) = 15.71 in. (399 mm)
width (d) = 25.42 in. (645.7 mm)
thickness = 1 in. (25.4 mm)

2 Sides

height (a) = 15.71 in. (399 mm)
depth (c) = 11.71 in. (297 mm)
thickness = 1 in. (25.4 mm)

— Driver Mounting —

Mounting: Front

HCCA122 & HCCA124 VENTED 1200 TO 2000 WATTS INPUT

Box Properties

— Description —

Type: Vented Box
Shape: Prism, Square

— Box Parameters —

Vb = 2.5 cu.ft
V(total) = 3.079 cu.ft
Fb = 38 Hz
QL = 5.256
F3 = 31 Hz
Fill = none

— Vents —

No. of Vents = 1
Vent shape = rectangle
Vent ends = one flush
Hv = 5 in. (127 mm)
Wv = 5 in. (127 mm)
Lv = 14.54 in. (369 mm)

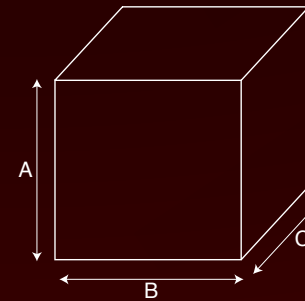

— External Dimensions —

A = 18 in. (457 mm)
B = 18 in. (457 mm)
C = 22.78 in. (579 mm)

— Internal Dimensions —

A = 16 in. (406 mm)
B = 16 in. (406 mm)
C = 20.78 in. (528 mm)

— Wall Thickness —

Front = 1 in. (25.4 mm)
Sides = 1 in. (25.4 mm)

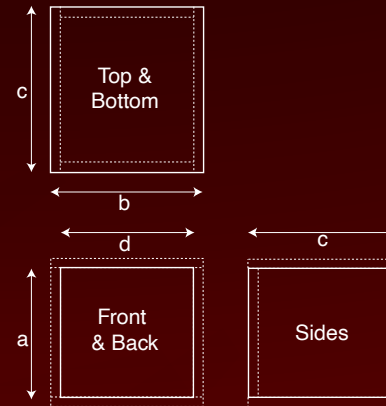

— Box Parts —

Box Shape – Square Prism

1 Top, 1 Bottom

depth (c) = 22.78 in. (579 mm)
width (b) = 18 in. (457 mm)
thickness = 1 in. (25.4 mm)

1 Front, 1 Back

height (a) = 16 in. (406 mm)
width (d) = 16 in. (406 mm)
thickness = 1 in. (25.4 mm)

2 Sides

height (a) = 16 in. (406 mm)
depth (c) = 22.78 in. (579 mm)
thickness = 1 in. (25.4 mm)

— Driver Mounting —

Mounting: Front

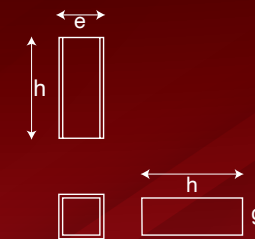

— Vent Parts —

1 Top, 1 Bottom

width (e) = 6.5 in. (165 mm)
length (h) = 14.54 in. (369 mm)
thickness = 0.75 in. (19 mm)

2 Sides

height (g) = 5 in. (127 mm)
length (h) = 14.54 in. (369 mm)
thickness = 0.75 in. (19 mm)

HCCA122 & HCCA124 VENTED 2000+ WATTS INPUT

Box Properties

— Description —

Type: Vented Box
Shape: Prism, Square

— Box Parameters —

Vb = 1.5 cu.ft
V(total) = 2.65 cu.ft
Fb = 40 Hz
QL = 5.256
F3 = 32.98 Hz
Fill = none

— Vents —

No. of Vents = 1
Vent shape = rectangle
Vent ends = one flush
Hv = 14 in. (356 mm)
Wv = 2 in. (51 mm)
Lv = 30.33 in. (770 mm)

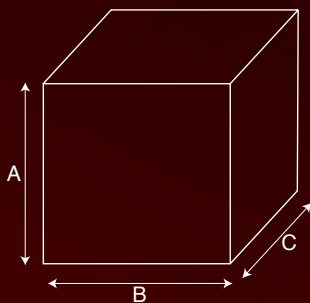

— External Dimensions —

A = 16 in. (406 mm)
B = 22 in. (559 mm)
C = 18.36 in. (466 mm)

— Internal Dimensions —

A = 14 in. (356 mm)
B = 20 in. (406 mm)
C = 16.36 in. (416 mm)

— Wall Thickness —

Front = 1 in. (25.4 mm)
Sides = 1 in. (25.4 mm)

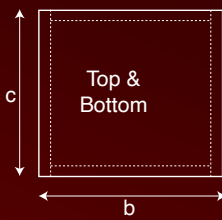

— Box Parts —

Box Shape – Square Prism

1 Top, 1 Bottom

depth (c) = 18.36 in. (466 mm)
width (b) = 22 in. (559 mm)
thickness = 1 in. (25.4 mm)

1 Front, 1 Back

height (a) = 14 in. (356 mm)
width (d) = 20 in. (406 mm)
thickness = 1 in. (25.4 mm)

2 Sides

height (a) = 14 in. (356 mm)
depth (c) = 18.36 in. (466 mm)
thickness = 1 in. (25.4 mm)

— Driver Mounting —

Mounting: Front

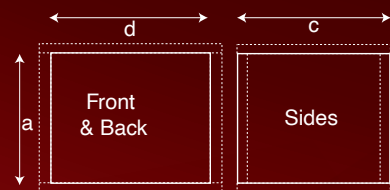

— Vent Parts —

1 Top, 1 Bottom

width (e) = 3.5 in. (89 mm)
length (h) = 30.33 in. (770 mm)
thickness = 0.75 in. (19 mm)

2 Sides

height (g) = 14 in. (356 mm)
length (h) = 30.33 in. (770 mm)
thickness = 0.75 in. (19 mm)

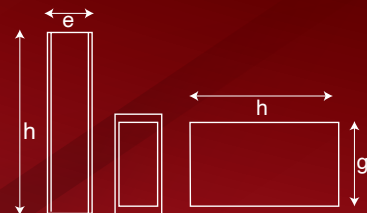

HCCA122 & HCCA124 VENTED SPL ENCLOSURE ONLY

Box Properties

— Description —

Type: Vented Box
Shape: Prism, Square

— Box Parameters —

Vb = 2 cu.ft
V(total) = 2.502 cu.ft
Fb = 57 Hz
QL = 5.256
F3 = 42.9 Hz
Fill = none

— Vents —

No. of Vents = 1
Vent shape = rectangle
Vent ends = one flush
Hv = 6 in. (152 mm)
Wv = 6 in. (152 mm)
Lv = 9.37 in. (238 mm)

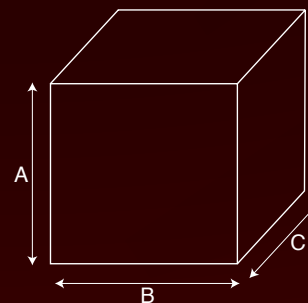

— External Dimensions —

A = 18 in. (457 mm)
B = 18 in. (457 mm)
C = 18.89 in. (480 mm)

— Internal Dimensions —

A = 16 in. (406 mm)
B = 16 in. (406 mm)
C = 16.89 in. (429 mm)

— Wall Thickness —

Front = 1 in. (25.4 mm)
Sides = 1 in. (25.4 mm)

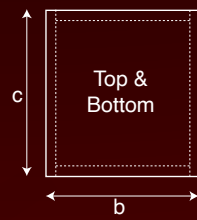

— Box Parts —

Box Shape – Square Prism

1 Top, 1 Bottom

depth (c) = 18.89 in. (480 mm)
width (b) = 18 in. (457 mm)
thickness = 1 in. (25.4 mm)

1 Front, 1 Back

height (a) = 16 in. (406 mm)
width (d) = 16 in. (406 mm)
thickness = 1 in. (25.4 mm)

2 Sides

height (a) = 16 in. (406 mm)
depth (c) = 18.89 in. (480 mm)
thickness = 1 in. (25.4 mm)

— Driver Mounting —

Mounting: Front

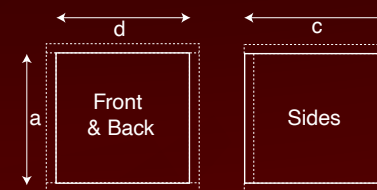

— Vent Parts —

1 Top, 1 Bottom

width (e) = 7.5 in. (191 mm)
length (h) = 9.37 in. (238 mm)
thickness = 0.75 in. (19 mm)

2 Sides

height (g) = 6 in. (152 mm)
length (h) = 9.37 in. (238 mm)
thickness = 0.75 in. (19 mm)

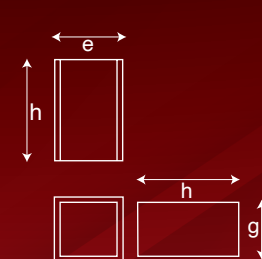

HCCA152 & HCCA154 SEALED ENCLOSURE

Box Properties

— Description —

Type: Closed Box
Shape: Prism, Square

— Box Parameters —

Vb = 3.64 cu.ft
QtC = 0.587
QL = 5
F3 = 45.39 Hz
Fill = none

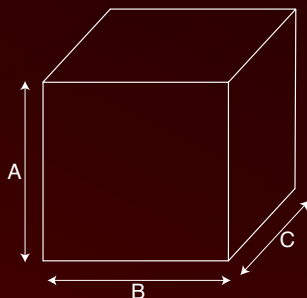

— External Dimensions —

A = 19.5 in. (495 mm)
B = 20 in. (508 mm)
C = 22 in. (559 mm)

— Internal Dimensions —

A = 17.5 in. (445 mm)
B = 18 in. (457 mm)
C = 20 in. (508 mm)

— Wall Thickness —

Front = 1 in. (25.4 mm)
Sides = 1 in. (25.4 mm)

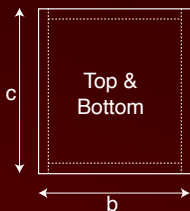

— Box Parts —

Box Shape – Square Prism

1 Top, 1 Bottom

depth (c) = 22 in. (559 mm)
width (b) = 20 in. (508 mm)
thickness = 1 in. (25.4 mm)

1 Front, 1 Back

height (a) = 17.5 in. (445 mm)
width (d) = 18 in. (457 mm)
thickness = 1 in. (25.4 mm)

2 Sides

height (a) = 17.5 in. (445 mm)
depth (c) = 22 in. (559 mm)
thickness = 1 in. (25.4 mm)

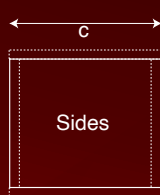
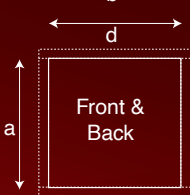

— Driver Mounting —

Mounting: Front

HCCA152 & HCCA154 VENTED 1200 TO 2000 WATTS INPUT

Box Properties

— Description —

Type: Vented Box
Shape: Prism, Square

— Box Parameters —

Vb = 4.5 cu.ft
V(total) = 5.32 cu.ft
Fb = 38 Hz
QL = 5
F3 = 27.7 Hz
Fill = none

— Vents —

No. of Vents = 1
Vent shape = rectangle
Vent ends = one flush
Hv = 7 in. (178 mm)
Wv = 7 in. (178 mm)
Lv = 14.07 in. (357 mm)

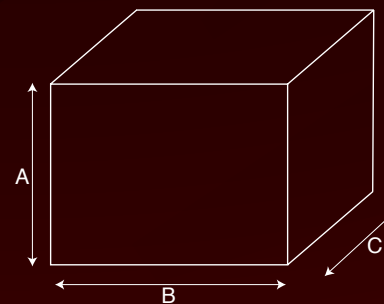

— External Dimensions —

A = 22.95 in. (583 mm)
B = 35.9 in. (912 mm)
C = 14.95 in. (378 mm)

— Internal Dimensions —

A = 20.95 in. (532 mm)
B = 33.9 in. (861 mm)
C = 12.95 in. (329 mm)

— Wall Thickness —

Front = 1 in. (25.4 mm)
Sides = 1 in. (25.4 mm)



— Box Parts —

Box Shape – Square Prism

1 Top, 1 Bottom

depth (c) = 14.95 in. (378 mm)
width (b) = 35.9 in. (912 mm)
thickness = 1 in. (25.4 mm)

1 Front, 1 Back

height (a) = 20.95 in. (532 mm)
width (d) = 33.9 in. (861 mm)
thickness = 1 in. (25.4 mm)

2 Sides

height (a) = 20.95 in. (532 mm)
depth (c) = 14.95 in. (378 mm)
thickness = 1 in. (25.4 mm)

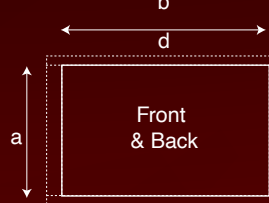

— Driver Mounting —

Mounting: Front



— Vent Parts —

1 Top, 1 Bottom

width (e) = 8.5 in. (216 mm)
length (h) = 14.07 in. (357 mm)
thickness = 0.75 in. (19 mm)

2 Sides

height (g) = 7 in. (178 mm)
length (h) = 14.07 in. (357 mm)
thickness = 0.75 in. (19 mm)



ENCLOSURE RECOMMENDATION

HCCA152 & HCCA154 VENTED 2000+ WATTS INPUT

Box Properties

— Description —

Type: Vented Box
Shape: Prism, Square

— Box Parameters —

Vb = 3.05 cu.ft
V(total) = 4.491 cu.ft
Fb = 38 Hz
QL = 5
F3 = 29.47 Hz
Fill = none

— Vents —

No. of Vents = 1
Vent shape = rectangle
Vent ends = one flush
Hv = 16 in. (406 mm)
Wv = 3 in. (76 mm)
Lv = 26.62 in. (676 mm)

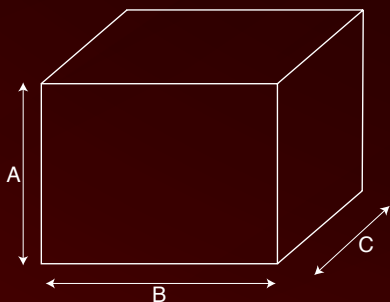

— External Dimensions —

A = 18 in. (457 mm)
B = 28 in. (711 mm)
C = 20.66 in. (525 mm)

— Internal Dimensions —

A = 16 in. (406 mm)
B = 26 in. (660 mm)
C = 18.66 in. (474 mm)

— Wall Thickness —

Front = 1 in. (25.4 mm)
Sides = 1 in. (25.4 mm)

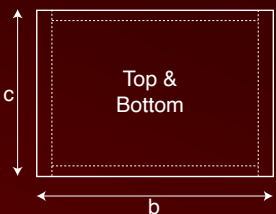

— Box Parts —

Box Shape — Square Prism

1 Top, 1 Bottom

depth (c) = 20.66 in. (525 mm)
width (b) = 28 in. (711 mm)
thickness = 1 in. (25.4 mm)

1 Front, 1 Back

height (a) = 16 in. (406 mm)
width (d) = 26 in. (660 mm)
thickness = 1 in. (25.4 mm)

2 Sides

height (a) = 16 in. (406 mm)
depth (c) = 20.66 in. (525 mm)
thickness = 1 in. (25.4 mm)

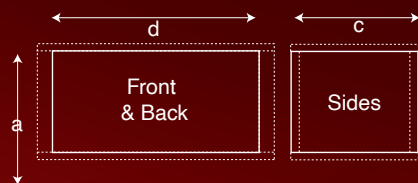

— Driver Mounting —

Mounting: Front

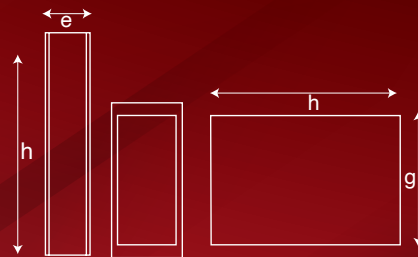

— Vent Parts —

1 Top, 1 Bottom

width (e) = 4.5 in. (114 mm)
length (h) = 26.62 in. (676 mm)
thickness = 0.75 in. (19 mm)

2 Sides

height (g) = 16 in. (406 mm)
length (h) = 26.62 in. (676 mm)
thickness = 0.75 in. (19 mm)

ENCLOSURE RECOMMENDATION

HCCA122 & HCCA124 VENTED SPL ENCLOSURE ONLY

Box Properties

— Description —

Type: Vented Box
Shape: Prism, Square
(optimum)

— Box Parameters —

Vb = 3.5 cu.ft
V(total) = 4.794 cu.ft
Fb = 57 Hz
QL = 5
F3 = 38.78 Hz
Fill = none

— Vents —

No. of Vents = 1
Vent shape = rectangle
Vent ends = one flush
Hv = 10 in. (254 mm)
Wv = 10 in. (254 mm)
Lv = 14.34 in. (364 mm)

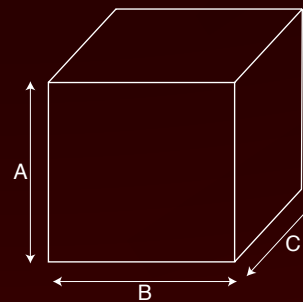

— External Dimensions —

A = 22.23 in. (565 mm)
B = 34.74 in. (882 mm)
C = 14.51 in. (369 mm)

— Internal Dimensions —

A = 20.23 in. (514 mm)
B = 32.74 in. (832 mm)
C = 12.51 in. (318 mm)

— Wall Thickness —

Front = 1 in. (25.4 mm)
Sides = 1 in. (25.4 mm)



— Box Parts —

Box Shape — Square Prism

1 Top, 1 Bottom

depth (c) = 14.51 in. (369 mm)
width (b) = 34.74 in. (882 mm)
thickness = 1 in. (25.4 mm)

1 Front, 1 Back

height (a) = 20.23 in. (514 mm)
width (d) = 32.74 in. (832 mm)
thickness = 1 in. (25.4 mm)

2 Sides

height (a) = 20.23 in. (514 mm)
depth (c) = 14.51 in. (369 mm)
thickness = 1 in. (25.4 mm)

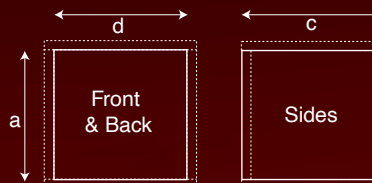

— Driver Mounting —

Mounting: Front

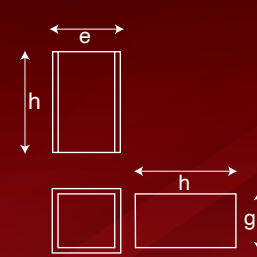

— Vent Parts —

1 Top, 1 Bottom

width (e) = 11.5 in.
length (h) = 14.34 in. (364 mm)
thickness = 0.75 in. (19 mm)

2 Sides

height (g) = 10 in. (254 mm)
length (h) = 14.34 in. (364 mm)
thickness = 0.75 in. (19 mm)

Investigate the layout of your vehicle thoroughly before drilling or cutting. Take care when you work near the gas tank, gas lines, hydraulic lines, electrical components and electrical wiring. Do not use the equipment unmounted. Attach this system securely to prevent damage, particularly in the event of an accident or aggressive driving. Do not mount the system so that wire connections are unprotected or are subjected to pinching or damage from nearby objects. Before connecting or disconnecting power connections at the system power terminals, disconnect the +12V DC wire at the battery end. Confirm that your source unit and other equipment are turned off while connecting the input terminals. If you need to replace the power fuse, replace it only with a fuse identical to the amperage recommended. Using a fuse of different type or rating may result in damage to the system, which is not covered by the manufacturer's warranty. Do not install any product where it may be subjected to excessive heat, moisture and dust or where it may be repeatedly kicked, brushed or bumped. Make absolutely sure that the terminals for the products are connected to the proper inputs and outputs from the music source. Never run the wiring on the outside of the vehicle or under it where it can be damaged by road hazards or any moving parts of the vehicle. Use existing wire channels, sills, panels and molding strips inside the vehicle to hide the wiring for safety and a neat appearance.

DISCLAIMER

IMPORTANT: Never cut any metal that is an integral part of the vehicle's safety or structural support system. If you are unsure, it is best to have the product professionally installed by an Authorized ORION Dealer. Never sacrifice your safety for sound.

Symptom	Check Point	Remedy
No Sound	Is the amplifier power LED illuminated?	1. Check fuses in amplifier 2. Check turn-on lead 3. Check signal lead 4. Check gain control 5. Check source unit volume 6. Clean contacts on fuse holders
	Is the amplifier overload LED illuminated?	Check speaker for short or amplifier for overheating
	Check impedance with Ohm meter	If no reading, replace speaker
	Check that the speaker moves freely	If speaker won't move, replace speaker
Speaker is making a rattling noise	Check that speaker is secured properly and tightened with screws	Tighten mounting screws
	Check enclosure construction	Check that the enclosure is debris free
	Check speaker polarity	Correct polarity
No sound from one coil	Check speaker leads	1. Inspect for short circuits 2. Check for open connections Reverse left and right speaker leads to determine if it is occurring before the speaker
Speaker is distorting at high volume levels	Check speaker load impedance capabilities for the amplifier	Confirm that the speaker load impedance recommendations are followed. Check the wiring configuration of the speaker. (To verify proper load impedance, use an OHM meter to measure the total load for each channel of the amplifier.
	Verify that amplifier and/or crossover settings are correct	Select low-pass setting

WARRANTY

Orion, warrants this product against all defects in material and workmanship for a period of one (1) year from the date of original purchase provided it was purchased from an Authorized Orion Dealer.

The conditions of this warranty and the extent of the responsibility of Orion, under this warranty are as follows:

1. DATED PROOF OF PURCHASE IS REQUIRED FOR WARRANTY SERVICE OF THIS PRODUCT. Information about Orion authorized warranty service may also be obtained at www.orioncaraudio.com or by emailing Orion at support@orioncaraudio.com.
2. This warranty will become void if service is performed by anyone other than an approved Orion Warranty Service Center.
3. This warranty does not apply to any product which has been subjected to misuse, neglect or accident, or which has had the warranty seal broken, serial number altered, defaced or removed, or which has been connected, installed adjusted or repaired other than in accordance with the instructions furnished by Orion.
4. This warranty does not cover car static, electrical interference, adjustments or labor costs for the removal or reinstallation of the unit for repair.
5. The sole responsibility of Orion under this warranty shall be limited to the repair or replacement thereof, at the sole discretion of Orion.
6. If it becomes necessary to send the product or any defective part to Orion or an authorized service station, the product must be shipped in its original or equivalent carton, fully insured, with shipping charges prepaid. Orion will not assume any responsibility for any loss or damage incurred in shipping.

WARRANTY

7. This warranty is not transferable and protects the original purchaser provided they reside and made their purchase in the United States. International consumers may contact their local retailer or distributor for warranty information.
8. ALL IMPLIED WARRANTIES, EXCEPT TO THE EXTENT PROHIBITED BY APPLICABLE LAW, SHALL HAVE NO GREATER DURATION THAN THE WARRANTY PERIOD SET FORTH ABOVE. UNDER NO CIRCUMSTANCES SHALL ORION BE LIABLE FOR ANY LOSS OR DAMAGE, DIRECT OR CONSEQUENTIAL, ARISING OUT OF THE USE OR INABILITY TO USE THE PRODUCT BECAUSE SOME STATES DO NOT ALLOW LIMITATIONS ON HOW LONG AN IMPLIED WARRANTY LASTS OR EXCLUSIONS OR LIMITATIONS OF INCIDENTAL OR CONSEQUENTIAL DAMAGES, THE ABOVE LIMITATIONS OR EXCLUSIONS MAY NOT APPLY TO YOU.
9. THIS WARRANTY GIVES YOU SPECIFIC LEGAL RIGHTS AND YOU MAY ALSO HAVE OTHER RIGHTS THAT VARY FROM STATE TO STATE.
10. Should you have any difficulties with the performance of this product during warranty or with any Orion authorized service center, you may contact Orion by emailing us at support@orioncaraudio.com.

ATTENTION

FOR ANY QUESTIONS, ISSUES, RETURNS OR WARRANTY

DO NOT contact the retailer, we recommend that you contact our service department for any and all assistance at support@orioncaraudio.com. We will do our best to resolve any problem in a professional and timely manner.

ORION

3130 WEST 15TH AVENUE HIALEAH, FLORIDA 33012

TEL: 786.464.0247 EMAIL: SUPPORT@ORIONCARAUDIO.COM ORIONCARAUDIO.COM

PROUD SPONSOR OF



Copyright ORION

All rights reserved. Any unauthorized reproduction or use of any Orion logos, images or design elements is strictly prohibited by law. Specifications subject to change without notice. REV. 26.2